

BAAN IVC4

**Definition of BEMIS 1.2a Import and Export
File for the Message Type Shipping schedule**

A publication of:

Baan Development B.V.
P.O.Box 143
3770 AC Barneveld
The Netherlands

Printed in the Netherlands

© Baan Development B.V. 1999.
All rights reserved.

The information in this document is subject to change without notice. No part of this document may be reproduced, stored or transmitted in any form or by any means, electronic or mechanical, for any purpose, without the express written permission of Baan Development B.V.

Baan Development B.V. assumes no liability for any damages incurred, directly or indirectly, from any errors, omissions or discrepancies between the software and the information contained in this document.

Document Information

Code: U7118E US
Group: User Documentation
Edition: E
Date: July 2000

Table of contents

1	General principles	1-1
	Available record types	1-1
	Branching diagram	1-2
	Key fields for outgoing messages	1-4
	Key fields for incoming messages	1-5
	Network directories	1-5
	BEMIS Messages – Conventions	1-7
	Changing the Date Format	1-8
	Changes in Comparison to Version 1.0.b	1-10
2	Data record description by record type	2-1
	SA1 Shipping Schedule Overhead – <i>Nachrichtenvorsatz</i>	2-1
	<i>Detailed description of Shipping Schedule, record type SA1 Overhead</i>	2-2
	SA2 Shipping Schedule Header – <i>Kopfdaten</i>	2-8
	<i>Detailed description of Shipping Schedule, record type SA2 Shipping Schedule Header</i>	2-12
	SA3 Shipping Schedule Text – <i>Textdaten</i>	2-33
	<i>Detailed description of Shipping Schedule, record type SA3 Shipping Schedule Text</i>	2-34
	SA4 Shipping Schedule Lines – <i>Positionsdaten</i>	2-38
	<i>Detailed description of Shipping schedule, record type SA4 Shipping Schedule Lines</i>	2-39
	SA5 Packaging Data - <i>Packmitteldaten</i>	2-44
	<i>Detailed description of Shipping Schedule, record type SA5 Packaging data</i>	2-49
3	Glossary of terms and abbreviations	3-1
4	Appendix	4-1
	Remarks about the conversion of plant/final delivery point in delivery address	4-1
	Sample file	4-3

Definition of BEMIS 1.1.a Import and Export File for the Message Type Shipping Schedule
ii

About this document

This documentation details the standard inhouse data formats, which the BAAN Electronic Message Interchange System BEMIS requires as interfaces to the appropriate EDI subsystem.

The documentation is intended for developers of EDI subsystems, which want to realize an interface of their software to BAAN IV. Furthermore, it supports consultants, who want to implement and verify such an interface within a customer project. Important fields are identified with both the English and German terms, to assist German-language speakers using this documentation.

Chapter 1 gives an overview over the general principles of the relevant EDI message. For example available record types, message structure, key fields and other conventions.

Chapter 2 details all corresponding record types for the EDI message. All data fields are listed in an overview table in connection with the corresponding table fields. In addition, every single field is more detailed. You will find information about the general conditions, which you need to observe for the processing in the EDI subsystem or in BAAN IV.

Changes in comparison with the previous version:

- Record type SA1 Shipping Schedule Overhead
No changes
- Record type SA2 Shipping Schedule Header
No changes
- Record type SA3 Shipping Schedule Text
The length of the text segments are extended from an..40 to an..70..
- Record Type SA4 Scheduling Lines
New Position has been added. Now it is possible to import the “RAN-Number”.
- Record Type SA5 Shipping Schedule Packaging Data
No changes

U7118E (July 2000) differences to U7118D

General Motors is substituting his old material planning system AMK worldwide by a new system MGO. This causes changes in EDIFACT Call Off messages and requires modifications of the BEMIS Inhouse Format.

- Record type SA2 Schedule Header
SA2.44 and SA2.45 are added to support GM MGO

Note: This modification is realized in the outgoing message FEINAB(Conversion Code FEINA6) and the incoming message FEINAB(Conversion Code FEINA6/FEINA7).

1 General principles

This section describes the BAAN EDI in-house format for the message type *Shipping schedule (incoming/outgoing)*.

Available record types

The use of the following kinds of data records is conditional (C) respectively mandatory (M), when you transmit information about shipping schedules by means of the message VDA 4915 (“*Datenfernübertragung von Lieferfeinabrufen*”)¹.

ID	Status	Name
SA1	M	Shipping Schedule Overhead (<i>Nachrichten-Vorsatz</i>)
SA2	M	Shipping Schedule Header (<i>Kopfdaten</i>)
SA3	C	Shipping Schedule Text (<i>Textdaten</i>)
SA4	M	Shipping Schedule Lines (<i>Abrufdaten</i>)
SA5	C	Shipping Schedule Packing Data (<i>Packmitteldaten</i>)

¹ Remote transmission of shipping schedules.

Branching diagram

The following data record structure is used for the message type BEMIS shipping schedule:

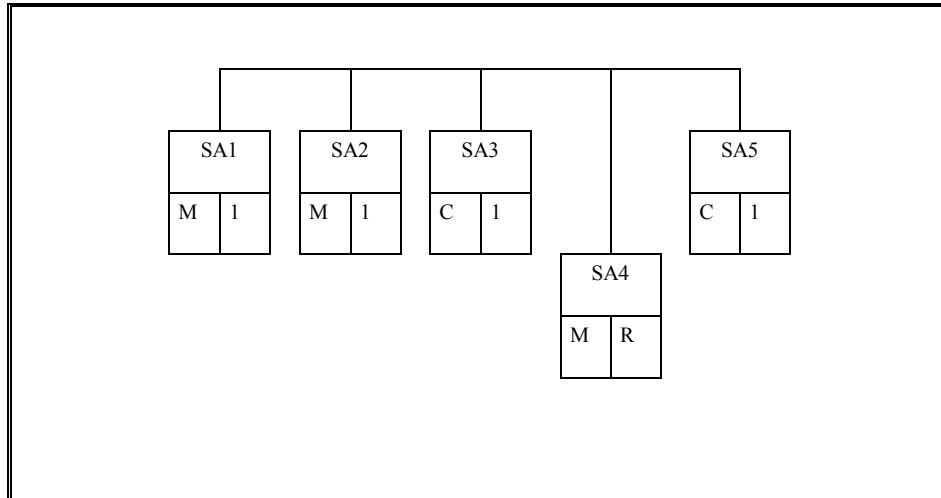

Legend:

Status: Frequency:

M: mandatory message 1: once in message

C: conditional message R: repeatable in message

Figure 1, Branching diagram

For example, for four required items the BEMIS file has the following structure:

```

SA1 ... BAAN IV Overhead
SA2 ... Supplier / customer and item data 1
SA3 ... Text
SA4 ... Date, quantity of item 1
SA4... Date, quantity of item 1
...
SA5 ...
SA5 ...

SA1 ... BAAN IV Overhead
SA2 ... Supplier / customer and item data 2
SA3 ... Text
SA4 ... Date, quantity of item 2
SA4... Date, quantity of item 2
...
SA5 ...
SA5 ...
    
```

```

SA1 ... BAAN IV Overhead
SA2 ... Supplier / customer and item data 3
SA3 ... Text
SA4 ... Date, quantity of item 3
SA4... Date, quantity of item 3
....
SA5 ...
SA5 ...

SA1 ... BAAN IV Overhead
SA2 ... Supplier / customer and item data 4
SA3 ... Text
SA4 ... Date, quantity of item 4
SA4... Date, quantity of item 4
....
SA5 ...
SA5 ...
    
```

Key fields for outgoing messages

The following structure of the key fields is used to determine the related data records of a shipping schedule:

Record type	Key field 1	Key field 2	Key field 3	Key field 4
SA1	Message reference			
SA2	Message reference	Identification supplier	Code plant customer	Customer's item number
SA3	Message reference	Identification supplier	Code plant customer	Customer's item number
SA4	Message reference	Identification supplier	Code plant customer	Customer's item number
SA5	Message reference	Identification supplier	Code plant customer	Customer's item number

Key fields for incoming messages

The following structure of the key fields is used to determine the related data records of a schedule message:

Record Type	Key field 1	Key field 2	Key field 3	Key field 4
SA1	Message reference	Network address customer		
SA2	Message reference	Network address customer	Code delivery address	Customer's item number
SA3	Message reference	Network address customer	Code delivery address	Customer's item number
SA4	Message reference	Network address customer	Code delivery address	Customer's item number
SA5	Message reference	Network address customer	Code delivery address	Customer's item number

Network directories

The so-called network directories form the basis of the communication between the EDI subsystem and BAAN IV. These directories are established in BAAN. The network basis directories for each network are defined in the BAAN session tcedi0120m000. For the network BEMIS, the basis directories can be indicated in the following way:

/auto3/baanIV/bemis/fab

BAAN will additionally create the following subdirectories:

/auto3/baanIV/bemis/fab/appl_from/
 /auto3/baanIV/bemis/fab/appl_to/
 /auto3/baanIV/bemis/fab/command/
 /auto3/baanIV/bemis/fab/store_rcv/
 /auto3/baanIV/bemis/fab/store_sent/
 /auto3/baanIV/bemis/fab/trace/

The above mentioned directories have the following function:

- 1 .../appl_from/: In this directory, BAAN IV records the outgoing messages which are the defined BEMIS inhouse format files. The EDI subsystem can collect them from here.
- 2 .../appl_to/: The EDI subsystem writes the incoming message into this directory in the BAAN IV inhouse format.
- 3 .../command/: Directory of the semaphores.
- 4 .../store_recv/: BAAN IV stores in this directory processed incoming messages, if the configuration is accordingly. During this process an additional subdirectory by incoming message file is created which is named with a date and time stamp indicating when the message was moved.
- 5 .../store_sent/: BAAN IV stores in this directory processed outgoing messages if the configuration is accordingly. During this process an additional subdirectory by incoming message file is created which is named with a date and time stamp indicating when the message was moved.
- 6 .../trace/: BAAN creates under this directory a log of the incoming and outgoing messages in the processing order, if the configuration is accordingly.

For every message type one network directory is used for outgoing and one for incoming messages. This means that one message file contains data for several business partners.

The file name of the BEMIS inhouse format file of the shipping schedule, which is being described in this documentation, is defined in the following way:

Direction	File name	Network directory
outgoing	FABOUT	../appl_from
incoming	FABIN	../appl_to

BEMIS Messages – Conventions

The following general rules apply to a message record in a BEMIS message file:

- 1 Every message record starts with “SAx“
- 2 Every message record ends with “SAx_END“
- 3 The length of a data record can vary.
- 4 The message record must consist of all fields, even if not every field contains a value.
- 5 The fields in the file must be separated by a ; .
- 6 All string fields have to be put in “...“.
- 7 The numerical values must not be put in “““.

In the following sections you will find the format descriptions for the individual record types of the interface file. The table contains the following data:

SHIPPING SCHEDULE INHOUSE FORMAT				
Pos	FIELD DESCRIPTION	Key	ST	FM

The first block of the table describes the format of a kind of data record:

Pos.	Position of the field in the data record
Field name	Description of the field
Key	Key field outgoing (O) / incoming (I)
ST	Field status mandatory (M) / conditional (C)
FM	Field format
an..14	alphanumeric field with a maximum of 14 characters
an14	alphanumeric field with exactly 14 characters
n..10	numerical field with a maximum of 10 characters
n1	numerical field with exactly 1 character

Mapping from (out) / to Application Table Fields (in)	
Table Field	Action

The second block of the table describes the corresponding table field in BAAN IV as well as possible special actions, which are carried out during the processing of the messages.

In the past, there seemed to be some doubts about the way BAAN points out a position within the message file. Here are some additional explanations:

As defined in BEMIS a position within a message file is pointed out using two semikolons.

To draw an example: "SAX";...;Position;...;"SAX_END"

If an position in a BEMIS Message File is not taken by a value (this means the position is empty), the position is pointed out as shown above. Moreover the BAAN EDI Module distinguishes between numerical and alphanumerical data format. If a position defined as numerical is empty the position is pointed out using semikolons. On the other hand empty alphanumerical positions are exported in two way. The first way is to point out a position using the semikolons. The second way BAAN exports empty alphanumerical positions is to write two inverted commans within the position. This depends whether the alphanumerical field existis in BAAN's database or not. Finally we take a look at the following expample:

empty numerical Position:

"SAX";...;;...;"SAX_END"

empty alphanumerical Position:

"SAX";...;;...;"SAX_END"

or

"SAX";...;"";...;"SAX_END"

Changing the Date Format

For the BAAN Versions b and c2/3 we have defined a date format using up to 6 numerical digits. Reading this definition, you will find out that the date format has been changed to 8 digits at maximum. With the BAAN Version BAAN IVC4 the delivered BEMIS default file the defaults.edi will be different in this point (in comparison to the versions delivered before). In BAAN EDI there is one global Parameter in order to send out date information including the two digits for the century.

The enclosed screen shots will show you where you will find the responsible parameter.

You have to choose the following menu option:

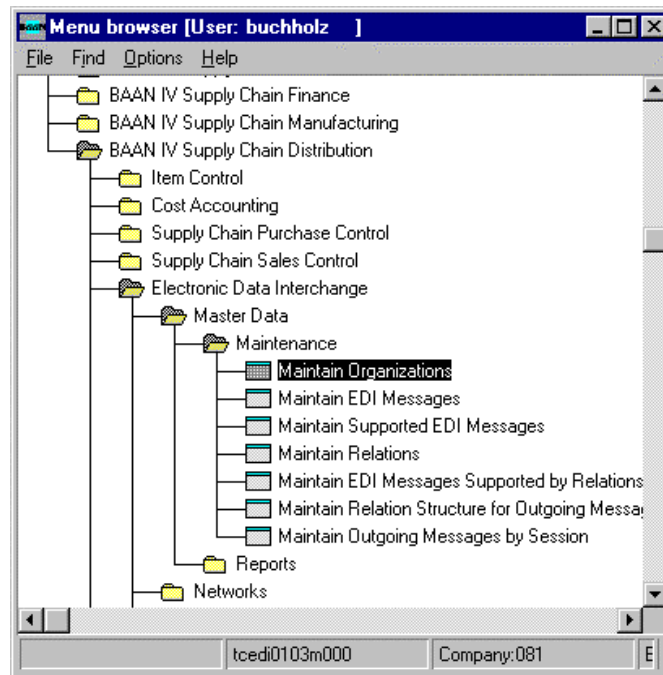

After you called the session tcedi0103m000 you will see that the entry for the dateformat on form two has been changed to “With Century (YYYYMMDD).

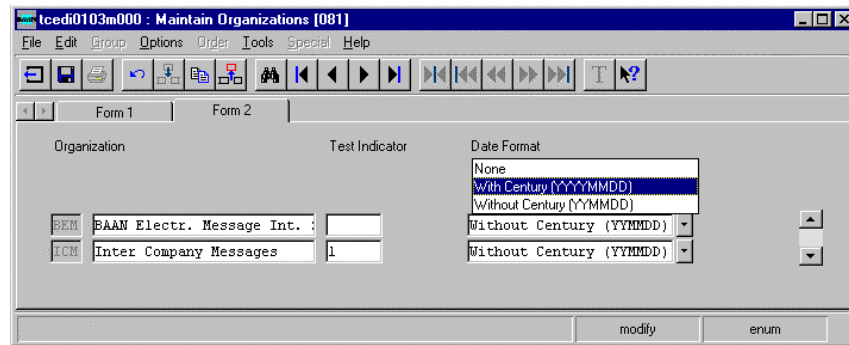

PLEASE NOTICE: If you use this option above the date format of every exported message will be changed to 8 digits! This means that the partner system (the translator software) has to be able to translate each outgoing message coming with the changed date format!

Following the table overview, every field is more detailed, including information about the processing in the EDI subsystem and in BAAN IV.

Changes in Comparison to Version 1.0.b

In comparison to version 1.0.b one new position has been added.

SA4:

SA4.10 The “RAN/ DON - Number ” is added. Thus it is now possible to import RAN Numbers.

SA4.11 The End of record sign “SA4_END” is moved from position 10 to position 11.

Furthermore the maximum length of the text fields has been extended. Here are the details:

SA3:

SA3.6 Text field length extended from an..40 to an..70

SA3.7 Text field length extended from an..40 to an..70

SA3.8 Text field length extended from an..40 to an..70

2 Data record description by record type

SA1 Shipping Schedule Overhead – Nachrichtenvorsatz

Status : Mandatory

Frequency : Once by message

Description: This data record contains information about the transmitter, the message type and the time of the transmission. The message reference identifies all related data records of this message.

SHIPPING SCHEDULE INHOUSE FORMAT					Mapping from Application Table Fields (out)		Mapping to Application Fields (in)	
Pos	FIELD DESCRIPTION	Key	ST	FM	Table Field	Action	Table Field	Action
1	Record type	O/I	M	an3	SA1		SA1	
2	Message reference	O/I	M	an..14	tcedi701.bano	Generation (see below)	tcedi702.bano	Generation by EDI subsystem
3	Network address customer / supplier		M	an..17	tcedi028.neta	Conversion (see below)	tcedi702.reno	Conversion (see below)
4	Our identification in the network		M	an..17	tcedi020.neta	Conversion (see below)	---	
5	Message		M	an..6	tcedi001.code	Conversion (see below)	tcedi702.mess	Conversion (see below)
6	Organisation		M	an..6	tcedi003.code	Conversion (see below)	tcedi702.orga	Conversion (see below)
7	Order type		M	an..35	tcedi011.koor	Conversion (see below)	tcedi702.koor	Conversion (see below)
8	Transmission reference		M	an..20	0		tcedi702.msno	
9	Date of transmission		M	n..8	current date		tcedi702.send	
10	Time of transmission		M	n..4	current time		tcedi702.sent	
11	Transmission reference old		M	an..20	0		tcedi702.prno	
12	Data record end sign		M	an7	SA1_END		SA1_END	

Detailed description of Shipping Schedule, record type SA1 Overhead

Position	1	Field format	an3	Field status	M
Field name	Record type		(Key field out/in)		

Description: This field identifies the kind of data record in the message block. It contains the fixed value 'SA1'.

Processing outgoing

EDI subsystem:

BAAN: This field is filled with the fixed value 'SA1'.

Processing incoming

EDI subsystem: This field is filled with the fixed value 'SA1'.

BAAN: None

Position	2	Field format	an..14	Field status	M
Field name	Message reference		(Key field out/in)		

Description: This field identifies all connected data records of one shipping schedule. The numbering, which has to be unambiguous by shipping schedule, helps to control the chronological order of the schedules and the complete transmission. The field consists of a fix part with four characters, the current date (format: YYYYMMDD) and a serial number with two characters.

The special format is defined in the network parameters in the BAAN table tcedi020.

Processing outgoing

EDI subsystem:

BAAN: BAAN generates this number to identify a shipping schedule, stores it in the BAAN table field tcedi701.bano and writes it into all data records of a shipping schedule.

Processing incoming

EDI subsystem: The EDI subsystem generates this number to identify a schedule and writes it into all data records of a schedule.

BAAN: Mapping to BAAN table field tcedi702.bano.

Position	3	Field format	an..17	Field status	M
Field name	Network address customer / supplier (Key field)				

Description: This field contains on the outgoing side the network address of the supplier and on the incoming side the network address of the customer.

Processing outgoing

EDI subsystem:

BAAN: The network address is stored in the BAAN table tcedi028 'Relations by network' under the corresponding business partner (supplier) and the corresponding network in the BAAN table field tcedi028.neta. The contents of this field is mapped to the position of the transmission file.

Processing incoming

EDI subsystem:

BAAN: The network address determines the corresponding business partner (customer) and the network in the table tcedi028 'Relations by network'. This identification is mapped to the BAAN table field tcedi702.reno.

Position	4	Field format	an..17	Field status	M
Field name	Our identification in the network				

Description: This field contains on the outgoing side our identification (customer) in the network.

Processing outgoing

EDI subsystem:

BAAN: The identification of the customer in the used network is entered in the table tcedi020 'Networks'. The BAAN table field TFtcedi028.neta is mapped to this position.

Processing incoming

EDI subsystem:

BAAN: On the incoming side this field is ignored.

Position	5	Field format	an..6	Field status	M
Field name	Message				

Description: This field contains the code for the identification of the concerned message. The code for the message type 'Shipping schedule' is FAB-IO.

Processing outgoing

EDI subsystem:

BAAN: The BAAN internal message code tcedi001.code 'FAB-IO' of the BAAN table tcedi001 'Supported EDI messages' is mapped to this position.

Processing incoming

EDI subsystem: This field is filled with the fixed value 'FAB-IO'.

BAAN: The message code in the table tcedi001 'Supported EDI Messages' determines, which internal message in BAAN is connected to this schedule. In the BAAN table tcedi005 'EDI Messages' is determined for every message which session (DII) is used in BAAN to process the shipping schedule. The message code is mapped to the BAAN table field Tftcedi702.mess.

Position	6	Field format	an..6	Field status	M
Field name	Organization				

Description: This field contains the organization (Standard) which is used for the EDI communication.

Processing outgoing

EDI subsystem:

BAAN: The internal organisation code tcedi003.code 'BEMIS' from the BAAN table tcedi003 'Organizations' is mapped to this position.

Processing incoming

EDI subsystem: This field is filled with the fixed value 'BEMIS'.

BAAN: Mapping to BAAN table field tcedi702.orga.

The corresponding organization must have been entered into the BAAN table tcedi003.

Position	7	Field format	an..35	Field status	M
Field name	Order type				

Description: This field contains a code for the concerned order type.

Processing outgoing

EDI subsystem:

BAAN: In the BAAN table tcedi011 there must be an entry for this order type in connection with the appropriate message and organization. The BAAN table field tcedi011.koor is mapped to this position. It is not filled at the moment.

Processing incoming

EDI subsystem: This position is not filled at the moment.

BAAN: Mapping to BAAN table field tcedi702.koor.

In the BAAN table tcedi200 there must be an entry for this order type in connection with the appropriate message and organization.

Position	8	Field format	an..20	Field status	M
Field name	Transmission Reference				

Description: This field contains the reference code which the EDI subsystem applied to this transmission.

Processing outgoing

EDI subsystem: Entry of the reference code for the transmission into the transmission file.

BAAN: The position is filled with 0 .

Processing incoming

EDI subsystem: Transmission of the value from the transmission file.

BAAN: Mapping to BAAN table field tcedi702.msno

Position	9	Field format	n..8	Field status	M
Field name	Date of transmission				

Description: This field contains on the outgoing side the current date, on which the schedule message was created. On the incoming side, this field contains the arrival date of the schedule at the EDI subsystem (format: YYYYMMDD).

Processing outgoing

EDI subsystem:

BAAN: Mapping of the current date to the position.

Processing incoming

EDI subsystem: Entry of the arrival date of the message at the EDI subsystem.

BAAN: Mapping to BAAN table field tcedi702.send

Position	10	Field format	n..4	Field status	M
Field name	Time of transmission				

Description: This field contains on the outgoing side the time, when the schedule message was created. On the incoming side, the field contains the arrival time of the schedule at the EDI subsystem (format: HHMM).

Processing outgoing

EDI subsystem:

BAAN: Mapping of the current time to the position.

Processing incoming

EDI subsystem: Entry of the arrival time of the message at the EDI subsystem.

BAAN: Mapping to BAAN table field tcedi702.send.

Position	11	Field format	an..20	Field status	M
Field name	Transmission reference old				

Description: This field contains the reference number, which the EDI subsystem applied to the previous transmission.

Processing outgoing

EDI subsystem: Entry of the reference code for the previous transmission into transmission file.

BAAN: The position is filled with 0.

Processing incoming

EDI subsystem: Transmission of the value from the transmission file.

BAAN: Mapping to BAAN table field tcedi702.prno

Position	12	Field format	an7	Field status	M
Field name	End of record marker				

Description: The field indicates the end of the record. It contains the fixed value 'SA1_END'.

Processing outgoing

EDI subsystem:

BAAN: The field is filled with the fixed value 'SA1_END'.

Processing incoming

EDI subsystem: The field is filled with the fixed value 'SA1_END'.

BAAN: None

SA2 Shipping Schedule Header – *Kopfdaten*

Status :	Mandatory
Frequency:	Once by item number
Description:	This kind of data record is used to transmit item number-specific data. The data record contains information about the previous schedule, the exact delivery address and information about schedule authorizations. All data records up to the next data record of the type SA2 refer to the same item number.

SHIPPING SCHEDULE INHOUSE FORMAT					Mapping from Application Table Fields (out)		Mapping to Application Fields (in)	
Pos	FIELD DESCRIPTION	Key	ST	FM	Table Field	Action	Table Field	Action
1	Record type	O/I	M	an3	SA2		SA2	
2	Message reference	O/I	M	an..14	tcedi701.bano		tcedi702.bano	
3	Supplier code (out)	O	M	an..6	tdpsc029.suno			Conversion (see below)
	Network address customer (in)	I	M	an..17			tcedi702.reno	
4	Code delivery address	O/I	M	an..20	tdpsc001.plnt + tdpsc001.delp		tdssc029.cdel	Generation by EDI subsystem Conversion based on qualifier in pos. 6 and 7 (see below)
5	Customer's item number	O/I	M	an..35	tdpsc029.item		tdssc029.item	Conversion based on qualifier in pos. 8 (see below)
6	Qualifier address code		M	an2	DP, here (...,"DP",...)		DP	
7	Qualifier address type		M	an2	ZZ, here (...,"ZZ",...)		ZZ	
8	Qualifier item number		M	an2	SA, here (...,"SA",...)		SA	
9	Customer's item number		M	an..35	tdpsc029.item		tdssc029.cпно	Key for search of contract.
10	Supplier's item number		CK	an..35	tdpsc029.cпно		tdssc029.txta	
11	Supplier's customer number		M	an..35	tccom020.ocus			
12	Customer's plant number		M	an..35	tdpsc001.plnt		tdssc029.plnt	Key for search for contract.
13	Final delivery point		M	an..32	tdpsc001.delp		tdssc029.delp	

SHIPPING SCHEDULE INHOUSE FORMAT					Mapping from Application Table Fields (out)		Mapping to Application Fields (in)	
Pos	FIELD DESCRIPTION	Key	ST	FM	Table Field	Action	Table Field	Action
14	Storage location (customer)		C	an..14	tdpsc001.cwar	In addition to final delivery point	tdssc029.cdoc	In addition to final delivery point
15	Line feed location		C	an..14	tdpsc001.lnfd		tdssc029.lnfd	
16	Shipping schedule number new		M	n..9	tdpsc029.dcin		tdssc029.scnn	
17	Shipping schedule date new		M	n..8	tdpsc029.isdt		tdssc029.isdt	
18	Use code		M	an1	tdpsc029.appc	Check of value range	tdssc029.appc	Check of value range
19	Signal critical stock level code		C	an1	Blank		tdssc029.txta	Check of value range
20	End date FAB time fence		C	n..8	Empty		tdssc029.txta	
21	Shipping schedule date type		M	an1	tdpsc001.deco	Check of value range	tdssc029.tdat	Check of value range
22	Order number		C	an..17	tdpsc029.cono		tdssc029.cono	
23	Discrepancy of cumulative		C	n..15	Empty		tdssc029.dcdf	Field format!
24	Actual cumulative quantity		M	n..10	tdpsc001.ydec		tdssc029.intc	
25	Last transaction date		M	n..8	tdpsc001.lded		tdssc029.dtbk	
26	Shipping note number last receipt		M	an..9	tdpsc007.dino		tdssc029.ides	
27	Shipping note date last receipt		M	n..8	tdpsc007.didt		tdssc029.ldat	
28	Shipping note quantity last receipt		M	n..9	tdpsc007.rqty		tdssc029.rcqt	
29	Status last receipt		M	an1	l	Check of value range	tdssc029.skey	Check of value range
30	Transaction date second last receipt		C	n..8	Empty		tdssc029.txta	
31	Shipping note number second last receipt		C	an..9	tdpsc007.dino		tdssc029.txta	

Definition of BEMIS 1.1.a Import and Export File for the Message Type Shipping Schedule

SHIPPING SCHEDULE INHOUSE FORMAT					Mapping from Application Table Fields (out)		Mapping to Application Fields (in)	
Pos	FIELD DESCRIPTION	Key	ST	FM	Table Field	Action	Table Field	Action
32	Shipping note date second last receipt		C	n..8	tdpsc007.didt		tdssc029.txta	
33	Shipping note quantity second last receipt		C	n..9	tdpsc007.rqty		tdssc029.txta	
34	Status second last receipt		C	an1	I	Check of value range	tdssc029.txta	Check of value range
35	Transaction date third last receipt		C	n..8	Empty		tdssc029.txta	
36	Shipping note number third last receipt		C	an..9	tdpsc007.dino		tdssc029.txta	
37	Shipping note date third last receipt		C	n..8	tdpsc007.didt		tdssc029.txta	
38	Shipping note quantity third last receipt		C	n..9	tdpsc007.rqty		tdssc029.txta	
39	Status third last receipt		C	an1	I	Check of value range	tdssc029.txta	Check of value range
40	Additional supplier		C	an..35		Text string	tdssc029.txta	
41	Additional item number		C	an..35		Text string	tdssc029.txta	
42	Actual cumulative quantity received		C	n..10	tdpsc001.cbar		tdssc029.iedi	
43	Date of annual reset (cums)		M	n..8	tdpsc001.rdat		tdssc029.iedi	
44	Cumulated quantity required (MGO)		C	n..12			tdssc029.iedi	
45	Date of cumulated quantity required (MGO)		C	n..8			tdssc029.iedi	
46	End of record marker		M	an7	SA2_END		SA2_END	

Detailed description of Shipping Schedule, record type SA2 Shipping Schedule Header

Position	1	Field format	an3	Field status	M
Field name	Record type		(Key field out/in)		

Description: This field identifies the kind of data record in the message block. It contains the fixed value 'SA2'.

Processing outgoing

EDI subsystem:

BAAN: This field is filled with the fixed value 'SA2'.

Processing incoming

EDI subsystem: This field is filled with the fixed value 'SA2'.

BAAN:

Position	2	Field format	an..14	Field status	M
Field name	Message reference		(Key field out/in)		

Description: This field identifies all connected data records of one shipping schedule. The numbering, which has to be unambiguous by shipping schedule, helps to control the chronological order of the schedules and the complete transmission.

Processing outgoing

EDI subsystem:

BAAN: Refer to record type SA1.

Processing incoming

EDI subsystem: Refer to record type SA1.

BAAN:

Position	3 out	Field format	an..6	Field status	M
Field name	Supplier code			(Key field out)	

Description: This field contains the identification code which the customer applied to the supplier.

Processing outgoing

EDI subsystem:

BAAN: Mapping of BAAN table field tdpsec029.suno to position.

Position	3 in	Field format	an..17	Field status	M
Field name	Network address customer			(Key field in)	

Description: This field contains the network address of the customer.

Processing incoming

EDI subsystem: Transmission of the value from the message file.

BAAN: The network address determines in the table tcedi028 'Relations by network' the corresponding business partner and network. The business partner identification is mapped to the BAAN table field tcedi702.reno.

Position	4	Field format	an..20	Field status	M
Field name	Code delivery address			(Key field out/in)	

Description: This field contains the code for the delivery address of the customer. The field consists of the *Plant* Code and the Code used for the *Final delivery point*. This position contains at maximum 20 characters.

Processing outgoing

EDI subsystem:

BAAN: BAAN generates this key on the basis of the data in tdpsec001.plnt and tdpsec001.delp. The length of this position will not be fix. At first the BAAN System writes the data of tdpsec001.plnt to the position followed by a blank. After that the data of tdpsec001.delp will be added.

Example for possible formats of this position:

Position																			
1	2	3	4	5	6	7	8	9	10	11	12	13	14	15	16	17	18	19	20
P	P	P		D	D	D	D	D	D										
P	P	P	P	P	P		D	D	D	D	D	D	D	D	D	D	D	D	



Blank



unused Position

Result in the message:

...;"PPP DDDDDD";...

...;"PPPPPP DDDDDDDDDDD";

P means code for plant D means code for delivery point

Mapping of the generated value to position.

Processing incoming

EDI subsystem: The EDI subsystem generates this key on the basis of the data in *Plant number Customer* and *Final delivery point*.

The format of this position should be the same as above.

BAAN: The conversion tables for the address codes can be found in the BAAN table *tcedi310* under the business partner and the *Organization* from data record SA1 and the *Address code-ID* from data record SA2. The BAAN internal address code of the generated *Code delivery address* is determined in this BAAN table and mapped to the BAAN table field *TFtdssc002.cdel*.

Position	5	Field format	an..35	Field status	M
Field name	Customer's Item Number			(Key field out/in)	

Description: This field contains the identification which the customer applied to the required item.

Processing outgoing

EDI subsystem:

BAAN: Mapping of BAAN field TFtdpsc002.item to position

Processing incoming

EDI subsystem:

BAAN: The conversion tables for the item numbers can be found in the BAAN table tcedi306 under the business partner and the *Organization* from data record SA1 and the *Item group-ID* from data record SA2. The BAAN internal item number of the transmitted *Customer's item number* is determined in this BAAN table and mapped to the BAAN table field TFtdssc002.item.

Position	6	Field format	an2	Field status	M
Field name	Qualifier Address Code				

Description: This field contains the qualifier address code which is used to determine the delivery address from the value in position 4. This position must be filled with the fixed value 'DP'.

Processing outgoing

EDI subsystem:

BAAN: This field is filled with the fixed value 'DP'.

Processing incoming

EDI subsystem: This field is filled with the fixed value 'DP'.

BAAN: The qualifier must have been entered in the BAAN table TBtcedi218 (Address code IDs). It is taken into account when the BAAN internal delivery address code is determined from the value in position 4.

Position	7	Field format	an2	Field status	M
Field name	Qualifier Address Type				

Description: This field contains the qualifier address type which is used to determine the delivery address from the value in position 4. This position must be filled with the fixed value 'ZZ'.

Processing outgoing

EDI subsystem:

BAAN: This field is filled with the fixed value 'ZZ'.

Processing incoming

EDI subsystem: This field is filled with the fixed value 'ZZ'.

BAAN: The qualifier must have been entered in the BAAN table TBtcedi224 (Address types). It is taken into account when the BAAN internal delivery address code is determined from the value in position 4.

Position	8	Field format	an2	Field status	M
Field name	Qualifier Item Number				

Description: This field contains the qualifier item number which is used to determine the item number from the *Customer's item number* in position 5. This position must be filled with the constant value 'SA' ('SA' = supplier's item number).

Processing outgoing

EDI subsystem:

BAAN: This field is filled with the fixed value 'SA'.

Processing incoming

EDI subsystem: This field is filled with the fixed value 'SA'.

BAAN: The qualifier must have been entered in the BAAN table TBtcedi232 (Item number IDs). It is taken into account when the BAAN internal item number is determined from the customer's item number in position 5.

Position	9	Field format	an..35	Field status	M
Field name	Customer's Item Number				

Description: This field contains the code of the customer plant to which the goods have to be delivered.

Processing outgoing

EDI subsystem:

BAAN: Mapping of BAAN field TFtdpsc001.plnt to position.

Processing incoming

EDI subsystem: Transmission of value from transmission file.

BAAN: Mapping to BAAN table field tdssc029.cpno.

Position	10	Field format	an..35	Field status	C
Field name	Supplier's item number				

Description: This field contains the identification which the supplier applied to the required item.

Processing outgoing

EDI subsystem:

BAAN: Mapping of BAAN table field tdpsc029.cпно to position.

Processing incoming

EDI subsystem: Transmission of value from transmission file.

BAAN: Mapping to BAAN table field tdssc029.txta.

Position	11	Field format	an..35	Field status	M
Field name	Supplier's customer number				

Description: This field contains the identification which the supplier applied to the customer.

Processing outgoing

EDI subsystem:

BAAN: Mapping of BAAN table field tcom020.ocus to position.

Processing incoming

EDI subsystem:

BAAN: No processing

Position	12	Field format	an..35	Field status	M
Field name	Customer's Plant Number				

Description: This field contains the key for the plant of the customer, to which the goods are to be delivered.

Processing outgoing

EDI subsystem:

BAAN: Mapping of BAAN table field tdpsc001.plnt to position.

Processing incoming

EDI subsystem: The EDI subsystem uses this field to generate the *code delivery address*.

Transmission of the value from the transmission file.

BAAN: Mapping to BAAN table field tdssc002.plnt.

Position	13	Field format	an..32	Field status	M
Field name	Final Delivery Point				

Description: This field contains the customer key for the final delivery point at the plant of the customer, to which the goods are to be delivered.

Processing outgoing

EDI subsystem:

BAAN: Mapping of BAAN table field tdpsc001.delp to position.

Processing incoming

EDI subsystem: The EDI subsystem uses this field to generate the *code delivery address*.

Transmission of the value from the transmission file.

BAAN: Mapping to BAAN table field tdssc002.delp.

Position	14	Field format	an..14	Field status	C
Field name	Storage location (customer)				

Description: This field contains the storage location of the customer as additional information for the *final delivery point*.

Processing outgoing

EDI subsystem:

BAAN: Mapping of BAAN table field tdpsc001.cwar to position.

Processing incoming

EDI subsystem: Transmission of the value from the transmission file.

BAAN: Mapping to BAAN table field tdssc002.cdoc

Position	15	Field format	an..14	Field status	C
Field name	Line feed location				

Description: This field contains the customer's identification of the location where the required material is consumed.

Processing outgoing

EDI subsystem:

BAAN: Mapping of BAAN table field tdpsc001.lnfd to position.

Processing incoming

EDI subsystem: Transmission of value from transmission file.

BAAN: Mapping to BAAN table field tdssc029.lnfd

Position	16	Field format	n..9	Field status	M
Field name	Shipping Schedule Number New				

Description: The customer applies a new number to each shipping schedule to be able to identify them. This number is entered into this field.

Processing outgoing

EDI subsystem:

BAAN: Mapping of BAAN table field tdpsc002.scnn to position.

Processing incoming

EDI subsystem: Transmission of value from transmission file.

BAAN: Mapping to BAAN table field tdssc029.scnn.

Position	17	Field format	n..8	Field status	M
Field name	Shipping Schedule Date New				

Description: This field contains the date when the shipping schedule was created by the customer (format: YYYYMMDD).

Processing outgoing

BAAN:

EDI subsystem: Mapping of BAAN table field tdpsc029.isdt to position.

Processing incoming

BAAN: Transmission of value from transmission file.

EDI subsystem: Mapping to BAAN table field tdssc029.isdt.

Position	18	Field format	an1	Field status	M
Field name	Use code				

Description: This field contains the encoded item status code/use code for the required item. The values of the VDA recommendation 4905 have to be used:

No information (<i>Keine Angaben</i>)	Blank
Series (<i>Serie</i>)	S
Substitute (<i>Ersatz allgemein</i>)	E
Series and substitute (<i>Serie und Ersatz</i>)	U
Trial (<i>Versuch</i>)	V
Pilot (<i>Pilot</i>)	P
Additional requirement (<i>Zusatzbedarf</i>)	Z
First sample (<i>Erstmuster</i>)	M
Sample (<i>Muster</i>)	Y
Other (<i>Sonstige</i>)	X

Processing outgoing

BAAN: Mapping of BAAN table field tdpsc001.appc to position.

EDI subsystem: Using the ODETTE-Standard you might need to convert the values.

Processing incoming

EDI subsystem: Transmission of value from transmission file.

Using the ODETTE-Standard you might need to convert the values.

BAAN: Mapping to BAAN table field tdssc029.appc.

Position	19	Field format	an1	Field status	C
Field name	Signal Critical Stock Level				

Description: This field indicates, if the stock level for the required item on customer side is critical or not. Allowed values:
 'C' = Critical
 Blank = Not critical

Processing outgoing

EDI subsystem:

BAAN: Position is filled with blank.

Processing incoming

EDI subsystem: Transmission of value from transmission file.

BAAN: Mapping to BAAN table field tdssc029.txta.

Position	20	Field format	n..8	Field status	C
Field name	End Date FAB time fence				

Description: This field indicates, until which date the shipping schedule will be valid (format: YYYYMMDD).

Processing outgoing

EDI subsystem:

BAAN: This field is not used at the moment.

Processing incoming

EDI subsystem: Transmission of value from transmission file.

BAAN: Mapping to BAAN table field tdssc029.txta

Position	21	Field format	an1	Field status	M
Field name	Type of shipping schedule date				

Description: This field contains the identification of the *Type of shipping schedule date* of the shipping schedule data in record type SA4. Allowed values:
 1 = Delivery At this date the required quantity has to be delivered at the customer's plant.
 2 = Pick-up At this date the required quantity has to be ready for pick-up at the supplier's plant.

Processing outgoing

EDI subsystem:

BAAN: Mapping of BAAN table field tdpsc001.deco to position. Used code and conversion table: TBtcedi484.

Processing incoming

EDI subsystem: The EDI subsystem sets the value on the basis of the data in the transmission file. If no value is transmitted, the system by default sets the value '1'.

BAAN: Mapping to BAAN table field tdssc002.tdat. Used code and conversion table: TBtcedi485.

Position	22	Field format	an..17	Field status	C
Field name	Order number				

Description: This field contains the identification which the customer applies to an order or to a contract.

Processing outgoing

EDI subsystem:

BAAN: Mapping of BAAN table field tdpsc029.cono to position.

Processing incoming

EDI subsystem: Transmission of value from transmission file.

BAAN: Mapping to BAAN table field tdssc029.cono

Position	23	Field format	n..15	Field status	C
Field name	Discrepancy of cumulative				

Description: This field contains the discrepancy of actual cumulative quantity and required cumulative quantity on customer side.

Field Format: NNNNNNNNNN.NNNN or
-NNNNNNNNN.NNNN

Processing outgoing

EDI subsystem:

BAAN: This position is not used at the moment.

Processing incoming

EDI subsystem: Transmission of value from transmission file.

BAAN: Mapping to BAAN table field tdssc029.dcdf. If the amount of the cumulative discrepancy is negative a minus sign has to be added to the value.

Position	24	Field format	n..10	Field status	M
Field name	Actual cumulative quantity				

Description: This field contains the actual cumulative quantity of this item, which includes all posted deliveries from the *date of annual reset (cums)* to the day of the current schedule calculation.

Processing outgoing

EDI subsystem:

BAAN: Mapping of BAAN table field tdpsc001.ydec to position.

Processing incoming

EDI subsystem: Transmission of value from transmission file.

BAAN: Mapping to BAAN table field tdssc029.intc.

Position	25	Field format	n..8	Field status	M
Field name	Last transaction date				

Description: Up to this date the customer has posted the delivery 'last receipt' of this item and integrated in his plannings (format: YYYYMMDD).

Processing outgoing

EDI subsystem:

BAAN: Mapping of BAAN table field tdpssc001.lided to position.

Processing incoming

EDI subsystem: Transmission of value from transmission file.

BAAN: Mapping to BAAN table field tdssc029.dtbk.

Position	26	Field format	n..6	Field status	M
Field name	Shipping note number last receipt				

Description: This field contains the shipping note number of the last delivery of this item, which the customer received and posted.

Processing outgoing

EDI subsystem:

BAAN: Mapping of BAAN table field tdpssc007.dino to position.

Processing incoming

EDI subsystem: Transmission of value from transmission file.

BAAN: Mapping to BAAN table field tdssc029.ides.

Position	27	Field format	n..8	Field status	M
Field name	Shipping note date last receipt				

Description: This field contains the shipping note date of the last delivery of this item, which the customer received and posted (format: YYYYMMDD).

Processing outgoing

EDI subsystem:

BAAN: Mapping of BAAN table field tdpssc007.didt to position.

Processing incoming

EDI subsystem: Transmission of value from transmission file.

BAAN: Mapping to BAAN table field tdssc029.ldat.

Position	28	Field format	n..9	Field status	M
Field name	Shipping note quantity last receipt				

Description: This field contains the shipping note quantity of the last delivery of this item, which the customer received and posted.

Processing outgoing

EDI subsystem:

BAAN: Mapping of BAAN table field tdpsc007.rqty to position.

Processing incoming

EDI subsystem: Transmission of value from transmission file.

BAAN: Mapping to BAAN table field tdssc029.rcqt.

Position	29	Field format	an1	Field status	M
Field name	Status last receipt				

Description: This field contains the status of the last delivery. Allowed values:
 'I' = The customer posted the transaction (actual).
 'P' = The customer has not yet posted the transaction. In this case, the transaction date equals the planned arrival date (planned).

Processing outgoing

EDI subsystem:

BAAN: This position is filled with the value 'I'.

Processing incoming

EDI subsystem: Transmission of value from transmission file.

BAAN: Mapping to BAAN table field tdssc029.skey.

Position	30	Field format	n..8	Field status	C
Field name	Transaction date second last receipt				

Description: This field contains the transaction date of the second last receipt of this item (format: YYYYMMDD).

Processing outgoing

EDI subsystem:

BAAN: This field is not used at the moment.

Processing incoming

EDI subsystem: Transmission of value from transmission file.

BAAN: Mapping to BAAN table field tdssc029.txta.

Position	31	Field format	n..6	Field status	C
Field name	Shipping note number second last receipt				

Description: This field contains the shipping note number of the second last receipt of this item, which the customer received and posted.

Processing outgoing

EDI subsystem:

BAAN: Mapping of BAAN table field tdpsc007.dino to position.

Processing incoming

EDI subsystem: Transmission of value from transmission file.

BAAN: Mapping to BAAN table field tdssc029.txta.

Position	32	Field format	n..8	Field status	C
Field name	Shipping note date second last receipt				

Description: This field contains the delivery date of the second last delivery of this item, which the customer received and posted (format: YYYYMMDD).

Processing outgoing

EDI subsystem:

BAAN: Mapping of BAAN table field tdpsc007.didt to position.

Processing incoming

EDI subsystem: Transmission of value from transmission file.

BAAN: Mapping to BAAN table field tdssc029.txta.

Position	33	Field format	n..9	Field status	C
Field name	Shipping note quantity second last receipt				

Description: This field contains the shipping note quantity of the second last delivery of this item, which the customer received and posted.

Processing outgoing

EDI subsystem:

BAAN: Mapping of BAAN table field tdpssc007.rqty to position.

Processing incoming

EDI subsystem: Transmission of value from transmission file.

BAAN: Mapping to BAAN table field tdssc029.txta

Position	34	Field format	an1	Field status	C
Field name	Status second last receipt				

Description: This field contains the status of the second last delivery.
 Allowed values:
 'I' = The customer posted the transaction (actual).
 'P' = The customer has not yet posted the transaction. In this case, the transaction date equals the planned arrival date (planned).

Processing outgoing

EDI subsystem:

BAAN: This position is filled with the value 'I'.

Processing incoming

EDI subsystem: Transmission of value from transmission file.

BAAN: Mapping to BAAN table field tdssc029.txta.

Position	35	Field format	n..8	Field status	C
Field name	Transaction date third last receipt				

Description: This field contains the transaction date of the third last receipt of this item (format: YYYYMMDD).

Processing outgoing

EDI subsystem:

BAAN: This field is not used at the moment.

Processing incoming

EDI subsystem: Transmission of value from transmission file.

BAAN: Mapping to BAAN table field tdssc029.txta.

Position	36	Field format	n..6	Field status	C
Field name	Shipping note number third last receipt				

Description: This field contains the shipping note number of the third last delivery of this item, which the customer received and posted.

Processing outgoing

EDI subsystem:

BAAN: Mapping of BAAN table field tdpsc007.dino to position.

Processing incoming

EDI subsystem: Transmission of value from transmission file.

BAAN: Mapping to BAAN table field tdssc029.txta.

Position	37	Field format	n..8	Field status	C
Field name	Shipping note date third last receipt				

Description: This field contains the shipping note date of the last delivery of this item, which the customer received and posted (format: YYYYMMDD).

Processing outgoing

EDI subsystem:

BAAN: Mapping of BAAN table field tdpsc007.didt to position.

Processing incoming

EDI subsystem: Transmission of value from transmission file.

BAAN: Mapping to BAAN table field tdssc029.txta.

Position	38	Field format	n..9	Field status	C
Field name	Shipping note quantity third last receipt				

Description: This field contains the shipping note quantity of the third last delivery of this item, which the customer received and posted

Processing outgoing

EDI subsystem:

BAAN: Mapping of BAAN table field tdpssc007.rqty to position.

Processing incoming

EDI subsystem: Transmission of value from transmission file.

BAAN: Mapping to BAAN table field tdssc029.txta.

Position	39	Field format	an1	Field status	C
Field name	Status third last receipt				

Description: This field contains the status of the third last delivery. Allowed values:
 'I' = The customer posted the transaction (actual).
 'P' = The customer has not yet posted the transaction. In this case, the transaction date equals the planned arrival date (planned).

Processing outgoing

EDI subsystem:

BAAN: The position is filled with the value 'I'.

Processing incoming

EDI subsystem: Transmission of value from transmission file.

BAAN: Mapping to BAAN table field tdssc029.txta.

Position	40	Field format	an..40	Field status	C
Field name	Additional supplier				

Description: This field contains the identification, which the customer applied to an additional supplier.

Processing outgoing

EDI subsystem:

BAAN: The position is filled with a text string.

Processing incoming

EDI subsystem: Transmission of value from transmission file.

BAAN: Mapping to BAAN table field tdssc029.txta.

Position	41	Field format	an..40	Field status	C
Field name	Additional item number				

Description: This field contains the additional item number which the customer applied to this item.

Processing outgoing

EDI subsystem:

BAAN: This position is filled with a text string.

Processing incoming

EDI subsystem: Transmission of value from transmission file.

BAAN: Mapping to BAAN table field tdssc029.txta.

Position	42	Field format	n..10	Field status	C
Field name	Actual cumulative quantity received				

Description: This field contains the actual cumulative quantity of this item prior to the last reset.

Processing outgoing

EDI subsystem:

BAAN: Mapping of BAAN table field tdpssc001.cbar to position.

Processing incoming

EDI subsystem: Transmission of value from transmission file.

BAAN: Mapping to BAAN table field tdssc029.iedi.

Position	43	Field format	n..8	Field status	M
Field name	Date of annual reset (cums)				

Description: This field contains the date, at which the actual cumulative quantity of that item was set back to zero the last time (format: YYYYMMDD).

Processing outgoing

EDI subsystem:

BAAN: Mapping of BAAN table field tdpssc001.rdat to position.

Processing incoming

EDI subsystem: Transmission of value from transmission file.

BAAN: Mapping to BAAN table field tdssc029.iedi.

Position	44	Field format	n..12	Field status	C
Field name	Cumulated quantity required (MGO)				

Description: This field contains the cumulated required quantity send by the customer .

Processing outgoing

EDI subsystem:

BAAN: None

Processing incoming

EDI subsystem: Transmission of the value from the transmission file.

BAAN: Mapping to BAAN table field tdssc029.iedi(4)

Position	45	Field format	n..8	Field status	C
Field name	Date of Cumulated quantity required (MGO)				

Description: This field contains the date related to the cumulated required quantity send by the customer (format: YYYYMMDD)

Processing outgoing

EDI subsystem:

BAAN: None

Processing incoming

EDI subsystem: Transmission of the value from the transmission file.

BAAN: Mapping to BAAN table field tdssc029.iedi(5)

Position	46	Field format	an7	Field status	M
Field name	End of record marker				

Description: The field indicates the end of the record. It contains the fixed value 'SA2_END'.

Processing outgoing

EDI subsystem:

BAAN: The field is filled with the fixed value 'SA2_END'.

Processing incoming

EDI subsystem: The field is filled with the fixed value 'SA2_END'.

BAAN: None

SA3 Shipping Schedule Text – *Textdaten*

Status : Conditional

Frequency : Repeatable by item number

Description: This data record supports the transmission of shipping schedule instructions for the supplier. These instructions are applied to the appropriate item, which is indicated in the previous data record SA2.

SHIPPING SCHEDULE INHOUSE FORMAT					Mapping from Application Table Fields (out)		Mapping to Application Fields (in)	
Pos	FIELD DESCRIPTION	Key	ST	FM	Table Field	Action	Table Field	Action
1	Record type	O/I	M	an3	SA3		SA3	
2	Message reference	O/I	M	an..14	tcedi701.bano		tcedi702.bano	
3	Supplier number (out)	O	M	an..6	tdpsc029.suno			
	Network address customer (in)	I	M	an..17			cedi702.reno	
4	Code delivery address	O/I	M	an..20	tdpsc001.plnt + tdpsc001.delp		tdssc029.cdel	
5	Customer's item code	O/I	M	an..35	tdpsc029.item		tdssc029.item	
6	Shipping Schedule Text 1		M	an..70	tdpsc029.txta		tdssc029.txta	
7	Shipping Schedule Text 2		C	an..70	tdpsc029.txta		tdssc029.txta	
8	Shipping Schedule Text 3		C	an..70	tdpsc029.txta		tdssc029.txta	
9	End of record marker		M	an7	SA3_END		SA3_END	

Detailed description of Shipping Schedule, record type SA3 Shipping Schedule Text

Position	1	Field format	an3	Field status	M
Field name	Record type		(Key field)		

Description: This field identifies the record type in the message block. It contains the fixed value 'SA3'.

Processing outgoing

EDI subsystem:

BAAN: This field is filled with the fixed value 'SA3'.

Processing incoming

EDI subsystem: This field is filled with the fixed value 'SA3'.

BAAN: None

Position	2	Field format	an..14	Field status	M
Field name	Message reference		(Key field)		

Description: This field identifies all connected data records of one shipping schedule. The numbering, which has to be unambiguous by shipping schedule, helps to control the chronological order of the schedules and the complete transmission.

Processing outgoing

EDI subsystem:

BAAN: Refer to record type SA2.

Processing incoming

EDI subsystem: Refer to record type SA2.

BAAN: Refer to record type SA2.

Position	3 out	Field format	an..6	Field status	M
Field name	Supplier number		(Key field)		

Description: This field contains the identification the customer applied to the supplier.

Processing outgoing

EDI subsystem:

BAAN: Refer to record type SA2.

Position	3 in	Field format	an..17	Field status	M
Field name	Network address customer		(Key field)		

Description: This field contains the network address of the customer.

Processing incoming

EDI subsystem: Refer to record type SA2.

BAAN: Refer to record type SA2.

Position	4	Field format	an..20	Field status	M
Field name	Code delivery address		(Key field)		

Description: This field contains the code for the delivery address of the customer.

Processing outgoing

EDI subsystem:

BAAN: Refer to record type SA2.

Processing incoming

EDI subsystem: Refer to record type SA2.

BAAN: Refer to record type SA2.

Position	5	Field format	an..35	Field status	M
Field name	Customer's item number				

Description: This field contains the identification which the customer applied to the required item.

Processing outgoing

EDI subsystem:

BAAN: Refer to record type SA2.

Processing incoming

EDI subsystem: Refer to record type SA2.

BAAN: Refer to record type SA2.

Position	6	Field format	an..70	Field status	M
Field name	Shipping schedule text 1				

Description: This field contains a shipping schedule text with 40 characters.

Processing outgoing

EDI subsystem:

BAAN: Mapping of BAAN table field tdpsc029.txta to position.

Processing incoming

EDI subsystem: Transmission of value from transmission file.

BAAN: Mapping to BAAN table field tdssc029.txta.

Position	7	Field format	an..70	Field status	C
Field name	Shipping schedule text 2				

Description: This field contains a shipping schedule text with 40 characters.

Processing outgoing

EDI subsystem:

BAAN: Mapping of BAAN table field tdpsc029.txta to position.

Processing incoming

EDI subsystem: Transmission of value from transmission file.

BAAN: Mapping to BAAN table field tdssc029.txta.

Position	8	Field format	an..70	Field status	C
Field name	Shipping schedule text 3				

Description: This field contains a shipping schedule text with 40 characters.

Processing outgoing

EDI subsystem:

BAAN: Mapping of BAAN table field tdpsc029.txta to position

Processing incoming

EDI subsystem: Transmission of value from transmission file.

BAAN: Mapping to BAAN table field tdssc029.txta.

Position	9	Field format	an7	Field status	M
Field name	End of record marker				

Description: The field indicates the end of the record. It contains the fixed value 'SA3_END'.

Processing outgoing

EDI subsystem:

BAAN: The field is filled with the fixed value 'SA3_END'.

Processing incoming

EDI subsystem: The field is filled with the fixed value 'SA3_END'.

BAAN: None

SA4 Shipping Schedule Lines – Positionsdaten

Status : Mandatory

Frequency: Repeatable by item number

Description: This record type supports the transfer of the required item quantity, which is indicated in the previous data record SA2. The customer determines the quantities which are required at certain dates.

SHIPPING SCHEDULE INHOUSE FORMAT					Mapping from Application Table Fields (out)		Mapping to Application Fields (in)	
Pos	FIELD DESCRIPTION	Key	ST	FM	Table Field	Action	Table Field	Action
1	Record type	O/I	M	an3	SA4		SA4	
2	Message reference	O/I	M	an..14	tcedi701.bano		tcedi702.bano	
3	Supplier number (out)	O	M	an..6	tdpsc001.suno			
	Network address customer (in)	I	M	an..17			tdssc029.cuno	
4	Code delivery address	O/I	M	an..20	tdpsc001.plnt + tdpsc001.delp		tdssc029.cdel	
5	Customer's item number	O/I	M	an..35	tdpsc029.item		tdssc029.item	
6	Shipping schedule date		M	n..8	tdssc030.date		tdssc030.date	
7	Shipping schedule time		M	n..4	tdssc030.time		tdssc030.time	
8	Shipping schedule quantity		M	n..9	tdssc030.dciq		tdssc030.dciq	
9	Requirement status		C	an1	B or Blank			
10	RAN.- / DON – umber		C	an..12	Emp / Position (...;..)		tds c030.ican	
11	End of record marker		M	an7	SA4_END		SA4_END	

Definition of BEMIS 1.1.a Import and Export File for the Message Type Shipping Schedule

Detailed description of Shipping schedule, record type SA4 Shipping Schedule Lines

Position	1	Field format	an3	Field status	M
Field name	Record type		(Key field)		

Description: This field identifies the kind of data record in the message block. It contains the fixed value 'SA4'.

Processing outgoing

EDI subsystem:

BAAN: This field is filled with the fixed value 'SA4'.

Processing incoming

EDI subsystem: This field is filled with the fixed value 'SA4'.

BAAN: None

Position	2	Field format	an..14	Field status	M
Field name	Message reference		(Key field)		

Description: This field identifies all connected data records of one shipping schedule. The numbering, which has to be unambiguous by shipping schedule, helps to control the chronological order of the schedules and the complete transmission.

Processing outgoing

EDI subsystem:

BAAN: Refer to record type SA2.

Processing incoming

EDI subsystem: Refer to record type SA2.

BAAN: Refer to record type SA2.

Position	3 out	Field format	an..6	Field status	M
Field name	Supplier number		(Key field)		

Description: This field contains the identification which the customer applied to the supplier.

Processing outgoing

EDI subsystem:

BAAN: Refer to record type SA2.

Position	3 in	Field format	an..17	Field status	M
Field name	Network address customer		(Key field)		

Description: This field contains the network address of the customer.

Processing incoming

EDI subsystem: Refer to record type SA2.

BAAN: Refer to record type SA2.

Position	4	Field format	an..20	Field status	M
Field name	Code delivery address		(Key field)		

Description: This field contains the code for the delivery address of the customer.

Processing outgoing

EDI subsystem:

BAAN: Refer to record type SA2.

Processing incoming

EDI subsystem: Refer to record type SA2.

BAAN: Refer to record type SA2.

Position	5	Field format	an..35	Field status	M
Field name	Customer's item number				

Description: This field contains the identification which the customer applied to the required item.

Processing outgoing

EDI subsystem:

BAAN: Refer to record type SA2.

Processing incoming

EDI subsystem: Refer to record type SA2.

BAAN: Refer to record type SA2.

Position	6	Field format	n..8	Field status	M
Field name	Shipping schedule date				

Description: This field contains the date for the requirement of this schedule position. It needs to be interpreted on the basis of the *Shipping schedule date type* of record type 2.

Processing outgoing

EDI subsystem:

BAAN: Mapping of BAAN table field tdpsc030.date to position.

Processing incoming

EDI subsystem:

BAAN: Mapping to BAAN table field tdssc030.date.

Position	7	Field format	n..4	Field status	M
Field name	Shipping schedule time				

Description: This field contains the time for the requirement of this schedule position. It needs to be interpreted on the basis of the *Schedule date type* of the record type 2.

Processing outgoing

EDI subsystem:

BAAN: Mapping of BAAN table field tdpsc030.time to position.

Processing incoming

EDI subsystem:

BAAN: Mapping to BAAN table field tdssc030.time.

Position	8	Field format	n..9	Field status	M
Field name	Shipping schedule quantity				

Description: This field contains the quantity of this schedule position.

Processing outgoing

EDI subsystem:

BAAN: Mapping of BAAN table field tdpsc030.dciq to position.

Processing incoming

EDI subsystem: The EDI subsystem transfers the quantity of this schedule position to this field.

BAAN: Mapping to BAAN table field tdssc030.dciq.

Position	9	Field format	an1	Field status	C
Field name	Requirement status				

Description: The requirement status indicates, until which date the supplier should keep die FAB data of the previous shipping schedule.

The value "B" indicates that the supplier should overtake the FAB data of the previous transmission until this date without any change. Only one position of every shipping schedule should have the value "B". All other positions have to be filled with blanks.

Processing outgoing

EDI subsystem:

BAAN: This field is filled with a blank.

Processing incoming

EDI subsystem:

BAAN:

Position	10	Field format	an..12	Field status	M
Field name	RAN - / DON Number				

Description: This field contains the RAN - / DON Number..

Processing outgoing

EDI subsystem: None.

BAAN: None; empty Position (...;...)

Processing incoming

EDI subsystem: The EDI subsystem transfers the RAN - / DON - Number to this field.

BAAN: Mapping to BAAN table field tdssc030.ican

Position	11	Field format	an7	Field status	M
Field name	End of record marker				

Description: The field indicates the end of the record. It contains the fixed value 'SA4_END'.

Processing outgoing

EDI subsystem:

BAAN: The field is filled with the fixed value 'SA4_END'.

Processing incoming

EDI subsystem: The field is filled with the fixed value 'SA4_END'.

BAAN: None

SA5 Packaging Data - *Packmitteldaten*

Status: Optional

Frequency: up to 4 times by item number outgoing
up to n times by item number incoming

BAAN IV purchase contracts contain a 4 level packaging structure, which can be transmitted by SA6. The first level represents the outer packaging, the other levels represent intermediate packaging and smaller packagings (level 4).

Description: This record type supports the transmission of packaging information, which can be used for the required item of the previous record of the data record SA2 (item number, capacity): This kind of data record is repeatable if several packagings have to be used.

1 Packaging level (outgoing) - All packagings (incoming)

SHIPPING SCHEDULE INHOUSE FORMAT					Mapping from Application Table Fields (out)		Mapping to Application Fields (in)	
Pos	FIELD DESCRIPTION	Key	ST	FM	Table Field	Action	Table Field	Action
1	Record type	O/I	M	an3	SA5	Evaluation expression P11	SA5	
2	Message reference	O/I	M	an..14	tcedi701.bano		tcedi702.bano	
3	Supplier number (out)	O	M	an..6	tdpsc001.suno			
	Network address customer (in)	I	M	an..17			cedi702.reno	
4	Code delivery address	O/I	M	an..20	tdpsc001.plnt + tdpsc001.delp		tdssc029.cdel	
5	Customer's item number	O/I	M	an..35	tdpsc029.item		tdssc029.item	
6	Customer's item number for packaging 1		M	an..35	tdpsc001.utyp	Evaluation expression P11	tdssc029.txta	
7	Supplier 's item number for packaging 1		C	an..35	tdpsc001.utyp	Evaluation expression P11	tdssc029.txta	
8	Quantity of items in package 1		M	n..9	tdpsc001.uqty	Evaluation expression P11	tdssc029.txta	
9	Flag 'Full packaging only 1'		M	n1	tdpsc001.iful	Evaluation expression P11	Blank	
10	End of record marker		M	an7	SA5_END		SA5_END	

2 Packaging level (outgoing)

SHIPPING SCHEDULE INHOUSE FORMAT					Mapping from Application Table Fields (out)	
Pos	FIELD DESCRIPTION	Key	ST	FM	Table Field	Action
1	Record type	O	M	an3	SA5	Evaluation expression PI2
2	Message reference	O	M	an..14	tcedi701.bano	
3	Supplier number (out) Network address customer (in)	O	M	an..6	tdpsc001.suno	
4	Code delivery address	O	M	an..20	tdpsc001.plnt + tdpsc001.delp	
5	Customer's item number	O	M	an..35	tdpsc029.item	
6	Customer's item number for packaging 2		M	an..35	tdpsc001.mtyp	Evaluation expression PI2
7	Customer's item number for packaging 2		C	an..35	tdpsc001.mtyp	Evaluation expression PI2
8	Quantity of items in package 2		M	n..9	tdpsc001.mqty	Evaluation expression PI2
9	Flag 'Full packaging only 2'		M	n1	tdpsc001.mful	Evaluation expression PI2
10	End of record marker		M	an7	SA5_END	

3 Packaging level (outgoing)

SHIPPING SCHEDULE INHOUSE FORMAT					Mapping from Application Table Fields (out)	
Pos	FIELD DESCRIPTION	Key	ST	FM	Table Field	Action
1	Record type	O	M	an3	SA5	Evaluation expression PI3
2	Message reference	O	M	an..14	tcedi701.bano	
3	Supplier number (out) Network address customer (in)	O	M	an..6	tdpsc001.suno	
4	Code delivery address	O	M	an..20	tdpsc001.plnt + tdpsc001.delp	
5	Customer's item number	O	M	an..35	tdpsc029.item	
6	Customer's item number for packaging 3		M	an..35	tdpsc001.btyp	Evaluation expression PI3
7	Customer's item number for packaging 3		C	an..35	tdpsc001.btyp	Evaluation expression PI3
8	Quantity of items in package 3		M	n..9	tdpsc001.bqty	Evaluation expression PI3
9	Flag 'Full packaging only 3'		M	n1	tdpsc001.bful	Evaluation expression PI3
10	End of record marker		M	an7	SA5_END	

4 Packaging level (outgoing)

SHIPPING SCHEDULE INHOUSE FORMAT					Mapping from Application Table Fields (out)	
Pos	FIELD DESCRIPTION	Key	ST	FM	Table Field	Action
1	Record type	O	M	an3	SA5_END	Evaluation expression PI4
2	Message reference	O	M	an..14	tcedi701.bano	
3	Supplier number (out) Network address customer (in)	O	M	an..6	tdpsc001.suno	
4	Code delivery address	O	M	an..20	tdpsc001.plnt + tdpsc001.delp	
5	Customer's item number	O	M	an..35	tdpsc029.item	
6	Customer's item number for packaging 4		M	an..35	tdpsc001.atyp	Evaluation expression PI4
7	Customer's item number for packaging 4		C	an..35	tdpsc001.atyp	Evaluation expression PI4
8	Quantity of items in package 4		M	n..9	tdpsc001.aqty	Evaluation expression PI4
9	Flag 'Full packaging only 4'		M	n1	tdpsc001.aful	Evaluation expression PI4
10	End of record marker		M	an7	SA5_END	

Remark about evaluation expressions:

The evaluation expressions indicate, if a special action needs to be carried out. In this case the evaluation expressions control, if a data record or certain field is written or not. They will only be written, when the corresponding fields in BAAN are filled:

PI1	Packaging information level 1 available	tdpsc001.utyp > ' '
PI2	Packaging information level 2 available	tdpsc001.mtyp > ' '
PI3	Packaging information level 3 available	tdpsc001.btyp > ' '
PI4	Packaging information level 4 available	tdpsc001.atyp > ' '

Detailed description of Shipping Schedule, record type SA5 Packaging data

Position	1	Field format	an3	Field status	M
Field name	Record type		(Key field)		

Description: This field identifies the kind of data record in the message block. It contains the fixed value 'SA5'.

Processing outgoing

EDI subsystem:

BAAN: This field is filled with the fixed value 'SA5'.

Processing incoming

EDI subsystem: This field is filled with the fixed value 'SA5'.

BAAN: None

Position	2	Field format	an..14	Field status	M
Field name	Message reference		(Key field)		

Description: This field identifies all connected data records of one shipping schedule. The numbering, which has to be unambiguous by shipping schedule, helps to control the chronological order of the schedules and the complete transmission.

Processing outgoing

EDI subsystem:

BAAN: Refer to record type SA2.

Processing incoming

EDI subsystem: Refer to record type SA2.

BAAN: Refer to record type SA2.

Position	3 out	Field format	an..6	Field status	M
Field name	Supplier number		(Key field)		

Description: This field contains the identification which the customer applied to the supplier.

Processing outgoing

EDI subsystem:

BAAN: Refer to record type SA2.

Position	3 in	Field format	an..17	Field status	M
Field name	Network address customer				(Key field)

Description: This field contains the network address of the customer.

Processing incoming

EDI subsystem: Refer to record type SA2.

BAAN: Refer to record type SA2.

Position	4	Field format	an..20	Field status	M
Field name	Code delivery address				(Key field)

Description: This field contains the code for the delivery address of the customer.

Processing outgoing

EDI subsystem:

BAAN: Refer to record type SA2.

Processing incoming

EDI subsystem: Refer to record type SA2.

BAAN: Refer to record type SA2.

Position	5	Field format	an..35	Field status	M
Field name	Customer's item number				

Description: This field contains the identification which the customer applied to the required item.

Processing outgoing

EDI subsystem:

BAAN: Refer to record type SA2.

Processing incoming

EDI subsystem: Refer to record type SA2.

BAAN: Refer to record type SA2.

Position	6	Field format	an..35	Field status	M
Field name	Customer's item number for packaging				

Description: This field contains the identification which the customer applied to the packaging for the required item.

Processing outgoing

EDI subsystem:

BAAN: Mapping of BAAN table field
TFtdpsc001.utyp/mtyp/btyp/atyp to position.

Processing incoming

EDI subsystem: Transmission of value from transmission file.

BAAN: Mapping to BAAN table field tdssc029.txta

Position	7	Field format	an..35	Field status	C
Field name	Supplier's item number for packaging				

Description: This field contains the identification number which the supplier applied to the packaging for the required item. This field contains the same values as the previous position, because in BAAN there is only one article number by packaging available.

Processing outgoing

EDI subsystem:

BAAN: Mapping of BAAN table field
TFtdpsc001.utyp/mtyp/btyp/atyp to position.

Processing incoming

EDI subsystem: Transmission of value from transmission file.

BAAN: Mapping to BAAN table field tdssc029.txta.

Position	8	Field format	n..9	Field status	M
Field name	Quantity of items in package				

Description: This field contains information about the capacity of the packaging.
The factor indicates how many units of the next smaller packaging are or can be included in this packaging (format: nnnnnn.nn).

Processing outgoing

EDI subsystem:

BAAN: Mapping of BAAN table field
TFtdpsc001.uqty/mqty/bqty/aqty to position.

Processing incoming

EDI subsystem: Transmission of value from transmission file.

BAAN: Mapping to BAAN table field tdssc029.txta.

Position	9	Field format	an1	Field status	M
Field name	Flag 'Full packaging only'				

Description: This field indicates if the packaging has to be filled completely.
'1' = Yes (packaging has to be full)
'2' = No

Processing outgoing

EDI subsystem:

BAAN: Mapping of BAAN table field tdpsc001.iful/mful/bful/aful to position.

Processing incoming

EDI subsystem:

BAAN: This field is ignored.

Position	10	Field format	an7	Field status	M
Field name	End of record marker				

Description: The field indicates the end of the record. It contains the fixed value 'SA5_END'.

Processing outgoing

EDI subsystem:

BAAN: The field is filled with the fixed value 'SA5_END'.

Processing incoming

EDI subsystem: The field is filled with the fixed value 'SA5_END'.

BAAN: None

3 Glossary of terms and abbreviations

ABRUF	Schedule
Appl	Application
ANSI	American National Standards Organization
BEM	Baan Electronic Message – abbreviated form of BEMIS used with the definition of the EDI organization
BEMIS	Baan Electronic Message Interchange System
business partner (BP)	Customer or supplier
C	Conditional, that is, optional message
defaults.edi	Export file detailing master EDI data
DELINS	Odette Delivery Instruction (Schedule)
Directory	Folder
EDI	Electronic Data Interchange; electronic exchange of documents in standard formats
EDIFACT	Electronic Data Exchange For Administration, Commerce and Transport. An ISO standard.
ELP	External Logistic partner
evaluation expression	If statement in the conversion setup for outgoing messages
ISO	International Standards Organization
ISO 4217	Code table
M	Mandatory (compulsory) message
MAIS	General Motor's interpretation of the subset of EDIFACT DELJIT Message
Messg	Message
network address	Folder (directory) path on network
ODDC	Odette Code Table
ODDC25	Odette Code Table 25
OJETTE	European standard for electronic data exchange
Org	Organization, that is, system
SCH	Supply Chain
Semaphore	Method to show a status using files with zero length

Translation	Conversion of one data format to another, for example Baan in-house data format to ODETTE
VAT	Value Added Tax (tax on turnover; sales tax)
VDA	Standard used for electronic data exchange in Germany
X12	Standard used for electronic data exchange in the United States

Definition of BEMIS 1.1.a Import and Export File for the Message Type Shipping Schedule

3-2

4 Appendix

Remarks about the conversion of plant/final delivery point in delivery address

When transmitting the messages:

- VDA4905 (Shipping schedule incoming)
- VDA 4915 (Shipping schedule incoming)
- VDA 4916 (Production sequence requirement incoming)

the features plant and final delivery point are expected respectively transmitted as unambiguous identification of the delivery point. BAAN uses an unambiguous delivery address without making any distinctions about final delivery points. Therefore, it is necessary for the above mentioned incoming messages to carry out a conversion of the combination plant/final delivery point into a certain delivery address in BAAN.

The following code- and conversion tables have to be used for the conversion:

1 Address types (tcedi214)

Maintain address types		Company: 600
<u>Organization</u>	: BEM BAAN Electr. Message Int. Sys.	
<u>Code in Message</u>	Description	
ZZ	Delivery address	Choice: ..

These parameters need to be entered once by organisation (BEM).

2 Address Code IDs (tcedi218)

Maintain Address Code IDs		Firma: 600
<u>Organization</u>	:	BEM BAAN Electr. Message Int. Sys.
<u>Code in Message</u>		Description
DP		Delivery address
		Choice: ..

These parameters need to be entered once by organization (BEM).

3 Delivery address codes by customer incoming (tcedi310)

Maintain Conv. Of Del. Addr. Codes by Customer (in)		Company: 600
<u>Customer</u>	:	000001 Volkswagen AG
<u>Organization</u>	:	BEM Verband der deutschen autoind.
<u>Address Code ID</u>	:	DP Delivery Address
<u>Code in Message</u>		Code in Application
01601QC		001 Werk Wolfsburg Tor1
01602QC		002 Werk Wolfsburg Tor2
		Choice: ..

The conversion of the plant/final delivery point into the delivery address (code in application) is entered into this table referring to one customer. The parameters have to be entered for every plant/final delivery point combination of one customer.

Sample file

```

"SA1";"F8009711240003";"005122";"F800";"FAB-
IO";"BEMIS";"";"Auftr.ref.";971124;1313;"Nach.ref. alt";"SA1_END"

"SA2";"F8009711240003";"005122";"WEKAblad";"MB1";"DP";"ZZ";"SA";"M
B1";"005122_MB1";"K005122";"WEK";"Ablad";"001";"Band1";100014;97112
4;"S";"
";"2";"100100";"0;971124;"LSNR001";971124;1000;"I";"";"971124;0;"I";"";
971124;0;"I";"ZwiLief."; "Erg. SachNr.";0;971124;"SA2_END"

"SA3";"F8009711240003";"005122";"WEKAblad";"MB1";"Liefertext
11111111111111111111111111111111";"Liefertext
22222222222222222222222222222222";"Liefertext
33333333333333333333333333333333";"SA3_END"

"SA4";"F8009711240003";"005122";"WEKAblad";"MB1";971124;1000;1000;"
";"1A";"SA4_END"

"SA4";"F8009711240003";"005122";"WEKAblad";"MB1";971125;1000;1000;"
";"SA4_END"

"SA4";"F8009711240003";"005122";"WEKAblad";"MB1";971126;1000;1000;"
";"2A";"SA4_END"

"SA4";"F8009711240003";"005122";"WEKAblad";"MB1";971127;1000;1000;"
";"3A";"SA4_END"

"SA4";"F8009711240003";"005122";"WEKAblad";"MB1";971128;1000;1000;"
";"4A";"SA4_END"

"SA4";"F8009711240003";"005122";"WEKAblad";"MB1";971129;1000;1000;"
";"5A";"SA4_END"

"SA4";"F8009711240003";"005122";"WEKAblad";"MB1";971130;1000;1000;"
";"6A";"SA4_END"

"SA4";"F8009711240003";"005122";"WEKAblad";"MB1";971201;1000;1000;"
";"7A";"SA4_END"

"SA4";"F8009711240003";"005122";"WEKAblad";"MB1";971201;1100;1000;"
";"8A";"SA4_END"

"SA4";"F8009711240003";"005122";"WEKAblad";"MB1";971201;1200;1000;"
";"9A";"SA4_END"

"SA4";"F8009711240003";"005122";"WEKAblad";"MB1";971201;1300;1000;"
";"10A";"SA4_END"

```

"SA5";"F8009711240003";"005122";"WEKAblad";"MB1";"0000100100";"0000100100";1;1;"SA5_END"

"SA1";"F8009712120043";"005122";"F800";"FAB-IO";"BEMIS";"";"Auftr.ref.";971212;1158;"Nach.ref. alt";"SA1_END"

"SA2";"F8009712120043";"005122";"WEKAblad";"MB1";"DP";"ZZ";"SA";"MB1";"005122_MB1";"";"WEK";"Ablad";"LADERAMPE";"Linie 1";100200;971212;"S";"KZ Krit. Best";"2";"100100";;0;971212;"";971212;0;"I";"";971212;0;"I";"ZwiLief."; "Erg. SachNr.";0;971212;"SA2_END"

"SA3";"F8009712120043";"005122";"WEKAblad";"MB1";"Liefertext1";"Liefer text 22222222222222222222222222222222";"222222";"SA3_END"

"SA4";"F8009712120043";"005122";"WEKAblad";"MB1";971212;0;0;"";"1B";;"SA4_END"

"SA4";"F8009712120043";"005122";"WEKAblad";"MB1";971212;1000;100;"";"2B";;"SA4_END"

"SA4";"F8009712120043";"005122";"WEKAblad";"MB1";971213;1000;100;"";"3B";;"SA4_END"

"SA4";"F8009712120043";"005122";"WEKAblad";"MB1";971214;1000;100;"";"4B";;"SA4_END"

"SA4";"F8009712120043";"005122";"WEKAblad";"MB1";971215;1000;100;"";"5B";;"SA4_END"

"SA4";"F8009712120043";"005122";"WEKAblad";"MB1";971216;0;100;"";"6B";;"SA4_END"

"SA4";"F8009712120043";"005122";"WEKAblad";"MB1";971217;1000;100;"";"7B";;"SA4_END"

"SA4";"F8009712120043";"005122";"WEKAblad";"MB1";971218;1000;100;"";"SA4_END"

"SA4";"F8009712120043";"005122";"WEKAblad";"MB1";971222;1000;100;"";"8B";;"SA4_END"

"SA4";"F8009712120043";"005122";"WEKAblad";"MB1";980101;1000;100;"";"9B";;"SA4_END"

"SA5";"F8009712120043";"005122";"WEKAblad";"MB1";"RACK";"RACK";1;1;"SA5_END"

"SA5";"F8009712120043";"005122";"WEKAblad";"MB1";"RACK1";"RACK1";1;2;"SA5_END"

Definition of BEMIS 1.1.a Import and Export File for the Message Type Shipping Schedule