

## **BAAN IVc4**

---

**Message Type Shipping Schedule  
(Definition of BEMIS 2.1 Inhouse Format)**

**A publication of:**

Baan Development B.V.  
P.O.Box 143  
3770 AC Barneveld  
The Netherlands

Printed in the Netherlands

© Baan Development B.V. 2001.  
All rights reserved.

The information in this document is subject to change without notice. No part of this document may be reproduced, stored or transmitted in any form or by any means, electronic or mechanical, for any purpose, without the express written permission of Baan Development B.V.

Baan Development B.V. assumes no liability for any damages incurred, directly or indirectly, from any errors, omissions or discrepancies between the software and the information contained in this document.

**Document Information**

Code: U7118G US  
Group: User Documentation  
Edition: G  
Date: July, 2003

# Table of contents

<b>1</b>	<b>General principles</b>	<b>1-1</b>
	Message and DLLs	1-1
	Available record types	1-1
	Branching diagram	1-2
	Key fields for outgoing messages	1-4
	Key fields for incoming messages	1-5
	Network directories	1-5
	BEMIS Messages – Conventions	1-7
	Changing the Date Format	1-9
	Changes in Comparison to Version 1.0.b	1-10
	Version 2.0 compared with Version 1.2.a	1-11
	Version 2.1 compared with Version 2.0	1-12
<b>2</b>	<b>Data record description by record type</b>	<b>2-1</b>
	SA1 Shipping Schedule Overhead	2-1
	<i>Detailed description</i>	2-2
	SA2 Shipping Schedule Header	2-8
	<i>Detailed description</i>	2-12
	SA3 Shipping Schedule Text	2-35
	<i>Detailed description</i>	2-36
	SA4 Shipping Schedule Lines	2-40
	<i>Detailed description</i>	2-41
	SA5 Packaging Data	2-48
	<i>Detailed description</i>	2-54
<b>3</b>	<b>Glossary of terms and abbreviations</b>	<b>3-1</b>
<b>4</b>	<b>Appendix</b>	<b>4-1</b>
	Remarks about the conversion of plant/final delivery point in delivery address	4-1
	Sample file	4-3

<b>Message Type Shipping Schedule</b>	<b>(Definition of BEMIS 2.1 Inhouse Format)</b>
<b>ii</b>	

# About this document

This documentation describes in detail the standard inhouse data formats, which the BAAN Electronic Message Interchange System BEMIS requires as interfaces to the appropriate EDI subsystem.

The documentation is intended for developers of EDI subsystems, which want to realize an interface of their software to BAAN IV. Furthermore, it supports consultants, who want to implement and verify such an interface within a customer project. Important fields are identified in English and German terms as well, to assist German-language speakers using this documentation.

Chapter 1 gives an overview over the general principles of the relevant EDI message. For example available record types, message structure, key fields and other conventions.

Chapter 2 details all corresponding record types for the EDI message. All data fields are listed in an overview table in connection with the corresponding table fields. In addition, every single field is more detailed. You find information about the general conditions, which you need to observe for the processing in the EDI subsystem or in BAAN IV.

Changes in comparison with the previous version:

- Record type SA1 Shipping Schedule Overhead  
No changes
- Record type SA2 Shipping Schedule Header  
No changes
- Record type SA3 Shipping Schedule Text  
The length of the text segments are extended from an..40 to an..70..
- Record Type SA4 Scheduling Lines  
New Position has been added. Now it is possible to import the “RAN-Number”.
- Record Type SA5 Shipping Schedule Packaging Data  
No changes

U7118E (July 2000) differences to U7118D

General Motors is substituting its old material planning system AMK worldwide by a new system MGO. This causes changes in EDIFACT Call Off messages and requires modifications of the BEMIS Inhouse Format.

- Record type SA2 Schedule Header  
SA2.44 and SA2.45 are added to support GM MGO

Note: This modification is realized in the outgoing message FEINAB(Conversion Code FEINA6) and the incoming message FEINAB(Conversion Code FEINA6/FEINA7).

June 2001 – U7118F differences to U7118E

This modified BEMIS setup is necessary to run the new BAAN IV Automotive Global Solution (AGS0).

**NOTE:** This modification is realized in the outgoing message FEINAB (Conversion Code V20)  
incoming message FEINAB (Conversion Code V20)

# 1 General principles

This section describes the BAAN EDI in-house format for the message type *Shipping schedule (incoming/outgoing)*.

## Message and DLLs

The corresponding message linked to organization BEM is called **FEINAB**.

The belonging DLLs are:

- tdsscdll5282 (incoming)
- tdpscdll4282 (outgoing)

## Available record types

The use of the following kinds of data records is conditional (C) respectively mandatory (M), when you transmit information about shipping schedules by means of the message VDA 4915 (*“Datenfernübertragung von Lieferfeinabrufen”*)<sup>1</sup>.

ID	Status	Name
SA1	M	Overhead
SA2	M	Shipping Schedule Header
SA3	C	Shipping Schedule Text
SA4	M	Shipping Schedule Lines
SA5	C	Shipping Schedule Packaging Data

---

<sup>1</sup> Remote transmission of shipping schedules.

## Branching diagram

The following data record structure is used for the message type BEMIS shipping schedule:

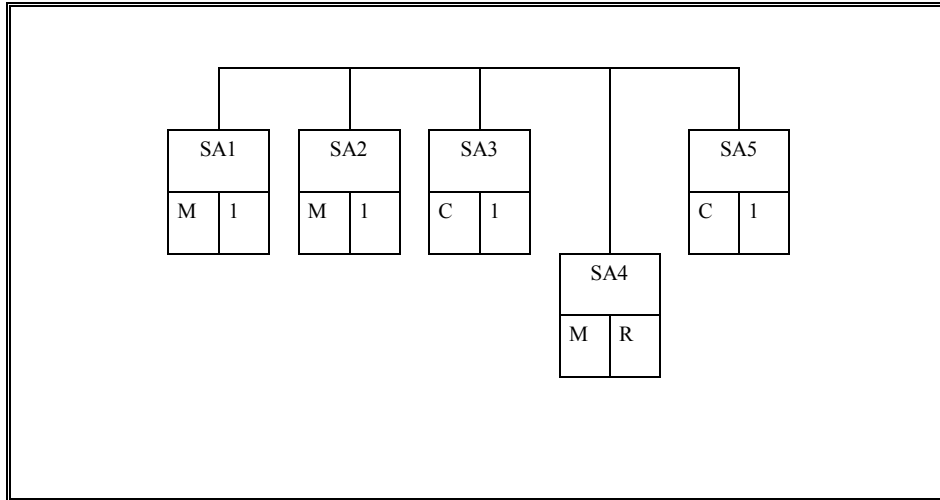

Legend:

Status:                      Frequency:

M: mandatory message      1: once in message

C: conditional message      R: repeatable in message

*Figure 1, Branching diagram*



For example, for four required items the BEMIS file has the following structure:

```

SA1 ... BAAN IV Overhead
SA2 ... Supplier / customer and item data 1
SA3 ... Text
SA4 ... Date, quantity of item 1
SA4... Date, quantity of item 1
...
SA5 ...
SA5 ...

SA1 ... BAAN IV Overhead
SA2 ... Supplier / customer and item data 2
SA3 ... Text
SA4 ... Date, quantity of item 2
SA4... Date, quantity of item 2
...
SA5 ...
SA5 ...

SA1 ... BAAN IV Overhead
SA2 ... Supplier / customer and item data 3
SA3 ... Text
SA4 ... Date, quantity of item 3
SA4... Date, quantity of item 3
....
SA5 ...
SA5 ...

SA1 ... BAAN IV Overhead
SA2 ... Supplier / customer and item data 4
SA3 ... Text
SA4 ... Date, quantity of item 4
SA4... Date, quantity of item 4
....
SA5 ...
SA5 ...
    
```

## Key fields for outgoing messages

The following structure of the key fields is used to determine the related data records of a shipping schedule:

<b>Record type</b>	<b>Key field 1</b>	<b>Key field 2</b>	<b>Key field 3</b>	<b>Key field 4</b>
SA1	Message reference	Identification supplier		
SA2	Message reference	Identification supplier		
SA3	Message reference	Identification supplier	Code plant customer	Customer's item number
SA4	Message reference	Identification supplier	Code plant customer	Customer's item number
SA5	Message reference	Identification supplier	Code plant customer	Customer's item number

## Key fields for incoming messages

The following structure of the key fields is used to determine the related data records of a schedule message:

Record Type	Key field 1	Key field 2	Key field 3	Key field 4
SA1	Message reference	Network address customer		
SA2	Message reference	Network address customer		
SA3	Message reference	Network address customer	Code delivery address	Customer's item number
SA4	Message reference	Network address customer	Code delivery address	Customer's item number
SA5	Message reference	Network address customer	Code delivery address	Customer's item number

## Network directories

The so-called network directories are the basis for the communication between the EDI subsystem and BAAN IV. These directories are located on the application server. The network basis directories for each network are defined in the BAAN session tcedi0120m000. For the network BEMIS they can be established in the following way:

Path = \${BSE}/edi/bemis/fab/

The following subdirectories will be created automatically:

\${BSE}/edi/bemis/fab/appl\_from/  
 \${BSE}/edi/bemis/fab/appl\_to/  
 \${BSE}/edi/bemis/fab/command/  
 \${BSE}/edi/bemis/fab/store\_rcv/  
 \${BSE}/edi/bemis/fab/store\_sent/  
 \${BSE}/edi/bemis/fab/trace/

The above mentioned directories have the following function:

- 1 `.../appl_from/`: In this directory, BAAN IV records the outgoing messages which are the defined BEMIS inhouse format files. The EDI subsystem can collect them from here.
- 2 `.../appl_to/`: The EDI subsystem writes the incoming message into this directory in the BAAN IV inhouse format.
- 3 `.../command/`: Directory of the semaphores.
- 4 `.../store_recv/`: BAAN IV stores in this directory processed incoming messages, if the configuration is accordingly. During this process an additional subdirectory by incoming message file is created which is named with a date and time stamp indicating when the message was moved.
- 5 `.../store_sent/`: BAAN IV stores in this directory processed outgoing messages if the configuration is accordingly. During this process an additional subdirectory by incoming message file is created which is named with a date and time stamp indicating when the message was moved.
- 6 `.../trace/`: BAAN creates under this directory a log of the incoming and outgoing messages in the processed order, if the configuration is accordingly.

For every message type one network directory is used for outgoing and one for incoming messages. This means that one message file contains data for several business partners.

The file name of the BEMIS inhouse format file of the shipping schedule, which is described in this documentation, is defined in the following way:

Direction	File name	Network directory
outgoing	FABOUT	<code>../appl_from</code>
incoming	FABIN	<code>../appl_to</code>

## BEMIS Messages – Conventions

The following general rules apply to a message record in a BEMIS message file:

- 1 Every message record starts with “SAx“
- 2 Every message record ends with “SAx\_END“
- 3 The length of a data record can vary.
- 4 The message record must consist of all fields, even if not every field contains a value.
- 5 The fields in the file must be separated by a ; .
- 6 All string fields have to be put in “...“.
- 7 The numerical values must not be put in “““.

In the following sections you will find the format descriptions for the individual record types of the interface file. The table contains the following data:

SHIPPING SCHEDULE INHOUSE FORMAT				
Pos	FIELD DESCRIPTION	Key	ST	FM

The first block of the table describes the general format of a data record:

Pos.	Position of the field in the data record
Field name	Description of the field
Key	Key field outgoing (O) / incoming (I)
ST	Field status mandatory (M) / conditional (C)
FM	Field format
an..14	alphanumeric field with a maximum of 14 characters
an14	alphanumeric field with exactly 14 characters
n..10	numerical field with a maximum of 10 characters
n1	numerical field with exactly 1 character

Mapping from (out) / to Application Table Fields (in)	
Table Field	Action

The second block of the table describes the corresponding table field in BAAN IV as well as possible special actions, which are carried out during the processing of the messages.

In the past, there seemed to be some doubts about the way BAAN points out a position within the message file. Here are some additional explanations:

As defined in BEMIS a position within a message file is pointed out using two semicolons.

Example: "SAX";...;Position;...;"SAX\_END"

If a position in a BEMIS Message File is not filled by a value (this means the position is empty), the position looks like shown below. The BAAN EDI Module distinguishes between numerical and alphanumerical data format. If a position defined as numerical is empty then the position is represented by two semicolons, one after another. On the other hand empty alphanumerical positions are exported in two ways. The first way is to point out a position using the semicolons, the second way is to write two quotation marks within the position. This depends whether the alphanumerical field exists in BAAN's database or not.

Example:

empty numerical Position:

"SAX";...;;...;"SAX\_END"

empty alphanumerical Position:

"SAX";...;;...;"SAX\_END"

or

"SAX";...;"";...;"SAX\_END"

## Changing the Date Format

For the BAAN Versions b and c2/3 the date format is defined by using up to 6 numerical digits. Reading this definition, you will find out that the date format has been changed to 8 digits at maximum. With the BAAN Version BAAN IVc4 the delivered BEMIS default file (defaults.edi) is different in this point (in comparison to the versions delivered before). In BAAN EDI there is one global parameter in order to send out date information including the two digits for the century.

The enclosed screen shots show where to find the corresponding parameters.

You have to choose the following menu option:

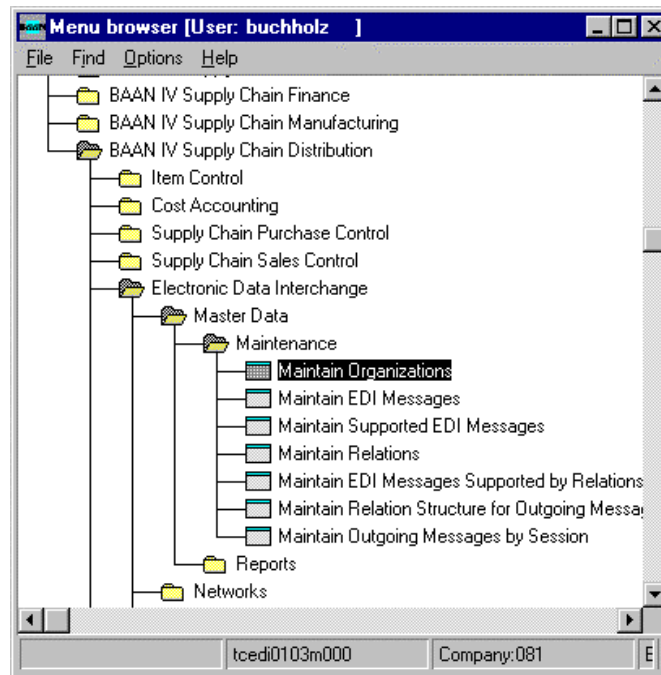

After you called the session tcedi0103m000 you see that the entry for the date format on form two has been changed to “With Century (YYYYMMDD).

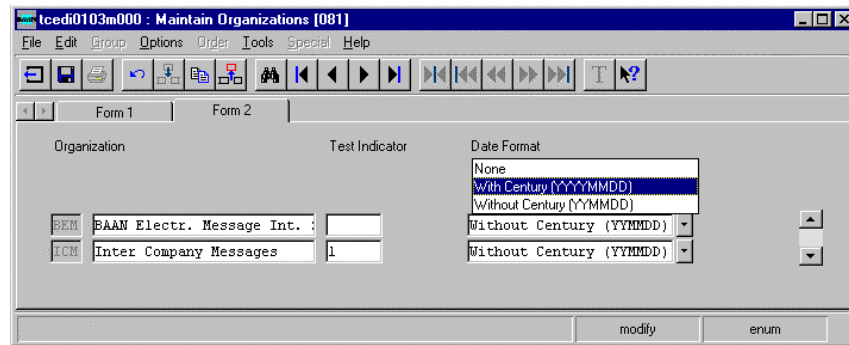

**PLEASE NOTICE:** If you use this option above the date format of every exported message will be changed to 8 digits! This means that the partner system (the translator software) has to be able to translate each outgoing message coming with the changed date format!

Following the table overview, every field is more detailed, including information about the processing in the EDI subsystem and in BAAN IV.

## Changes in Comparison to Version 1.0.b

In comparison to version 1.0.b one new position has been added.

### SA4:

SA4.10 The “RAN/ DON - Number ” is added. Thus it is now possible to import RAN Numbers.

SA4.11 The End of record sign “SA4\_END” is moved from position 10 to position 11.

Furthermore the maximum length of the text fields has been extended. Here are the details:

### SA3:

SA3.6 Text field length extended from an..40 to an..70

SA3.7 Text field length extended from an..40 to an..70

SA3.8 Text field length extended from an..40 to an..70



## Version 2.0 compared with Version 1.2.a

The new version 2.0 , based on version 1.2.a, is necessary to run the new BAAN IV Automotive Global Solution (AGS0).

### Changes SA2 – Shipping Schedule Header Data

Field number	Outgoing	Incoming
4 – change	The combination of tdpsc001.plnt and tdpsc001.delp will be mapped to tdpsc004.plnt instead of tdpsc229.iedi(5)	No change
44 – change	No change	Mapping to tdssc229.creq instead of tdssc229.iedi(4)
45 – change	No change	Mapping to tdssc229.dtbk instead of tdssc229.iedi(5)
46 – new	NA	Mapping to tdssc229.pups
47 – new	NA	Mapping to tdssc229.hdtf
48 – new	NA	Mapping to tdssc229.hdtf
49 – new	Data record end sign (old position was 46)	NA

### Changes SA4 – Shipping Schedule Lines

Field number	Outgoing	Incoming
11 – new	NA	Mapping to tdssc230.fsdt
12 – new	NA	Mapping to tdssc230.fsti
13 – new	NA	Mapping to tdssc230.lsd
14 – new	NA	Mapping to tdssc230.lsti
15 – new	Data record end sign (old position was 11)	NA

**Changes SA5 – Shipping Schedule Packaging Data**

Field number	Outgoing	Incoming
6 – change	NA	Mapping to tdssc231.cpak instead of tdssc229.txta
7 – change	NA	Mapping to tdssc231.pack instead of tdssc229.txta
8 – change	NA	Mapping to tdssc231.cqty instead of tdssc229.txta
10– new	SA	Used as qualifier for item conversion
11 – new	1, 2 or 3	Mapping to tdssc231.plvl
12 – new	M or A	Mapping to tdssc231.ptyp
13 – new	NA	Mapping to tdssc231.puqt
14 – new	tdpsc001.cuqp	Mapping to tdssc231.cuqs
15 – new	NA	Mapping to tdssc231.dsca
16 – new	NA	Mapping to tdssc231.clra
17 – new	Data record end sign (old position was 10)	NA

**Version 2.1 compared with Version 2.0**

The new version 2.1 has the same message structure as version 2.0.  
 No new fields are added, only two source fields on the outgoing site are replaced.

**Changes SA2 – Shipping Schedule Header Data**

Field number	Outgoing	Incoming
24 – change	Received Quantity tdpsc029.recq replaces tdpsc001.ydeq	No change
25 – change	Receipt Date tdpsc007.date replaces tdpsc001.lded	No change

## 2 Data record description by record type

### SA1 Shipping Schedule Overhead

Status : Mandatory

Frequency : Once by message

Description: This data record contains information about the transmitter, the message type and the time of the transmission. The message reference identifies all related data records of this message.

SHIPPING SCHEDULE INHOUSE FORMAT					Mapping from Application Table Fields (out)		Mapping to Application Fields (in)	
Pos	FIELD DESCRIPTION	Key	ST	FM	Table Field	Action	Table Field	Action
1	Record type	O/I	M	an3	SA1		SA1	
2	Message reference	O/I	M	an..14	tcedi701.bano	Generation (see below)	tcedi702.bano	Generation by EDI subsystem
3	Network address customer / supplier		M	an..17	tcedi028.neta	Conversion (see below)	tcedi702.reno	Conversion (see below)
4	Our identification in the network		M	an..17	tcedi020.neta	Conversion (see below)	---	
5	Message		M	an..6	tcedi001.code	Conversion (see below)	tcedi702.mess	Conversion (see below)
6	Organization		M	an..6	tcedi003.code	Conversion (see below)	tcedi702.orga	Conversion (see below)
7	Order type		M	an..35	tcedi011.koor	Conversion (see below)	tcedi702.koor	Conversion (see below)
8	Transmission reference		M	an..20	0		tcedi702.msno	
9	Date of transmission		M	n..8	current date		tcedi702.send	
10	Time of transmission		M	n..4	current time		tcedi702.sent	
11	Transmission reference old		M	an..20	0		tcedi702.prno	
12	Data record end sign		M	an7	SA1_END		SA1_END	

## Detailed description

Position	<b>1</b>	Field format	<b>an3</b>	Field status	<b>M</b>
Field name	<b>Record type</b>			(Key field out/in)	

Description: This field identifies the kind of data record in the message block. It contains the fixed value 'SA1'.

Processing outgoing

EDI subsystem:

BAAN: This field is filled with the fixed value 'SA1'.

Processing incoming

EDI subsystem: This field is filled with the fixed value 'SA1'.

BAAN: None

Position	<b>2</b>	Field format	<b>an..14</b>	Field status	<b>M</b>
Field name	<b>Message reference</b>			(Key field out/in)	

Description: This field identifies all connected data records of one shipping schedule. The numbering, which has to be unique by shipping schedule, helps to control the chronological order of the shipping schedules and the complete transmission. The field consists of a fix part with four characters, the current date (format: YYYYMMDD) and a serial number with two characters. The specific format is defined in the network parameters in the BAAN table tcedi020.

Processing outgoing

EDI subsystem:

BAAN: BAAN generates this number to identify a shipping schedule, stores it in the BAAN table field tcedi701.bano and writes it into all data records of a shipping schedule.

Processing incoming

EDI subsystem: The EDI subsystem generates this number to identify a schedule and writes it into all data records of a shipping schedule.

BAAN: Mapping to BAAN table field tcedi702.bano.

Position	<b>3</b>	Field format	<b>an..17</b>	Field status	<b>M</b>
Field name	<b>Network address customer / supplier</b> (Key field)				

Description: This field contains on the outgoing side the network address of the supplier and on the incoming side the network address of the customer.

Processing outgoing

EDI subsystem:

BAAN: The network address is stored in the BAAN table tcedi028 'Relations by network' under the corresponding business partner (supplier) and the corresponding network in the BAAN table field tcedi028.neta. The content of this field is mapped to the position of the transmission file.

Processing incoming

EDI subsystem:

BAAN: The network address determines the corresponding business partner (customer) and the network in the table tcedi028 'Relations by network'. This identification is mapped to the BAAN table field tcedi702.reno.

Position	<b>4</b>	Field format	<b>an..17</b>	Field status	<b>M</b>
Field name	<b>Our identification in the network</b>				

Description: This field contains on the outgoing side the customer's identification in the network.

Processing outgoing

EDI subsystem:

BAAN: The identification of the customer in the used network is entered in the table tcedi020 'Networks'. The BAAN table field tcedi028.neta is mapped to this position.

Processing incoming

EDI subsystem:

BAAN: On the incoming side this field is ignored.

Position	<b>5</b>	Field format	<b>an..6</b>	Field status	<b>M</b>
Field name	<b>Message</b>				

Description: This field contains the code for the identification of the concerned message. The code for the message type 'Shipping schedule' is FAB-IO.

Processing outgoing

EDI subsystem:

BAAN: The BAAN internal message code tcedi001.code 'FAB-IO' of the BAAN table tcedi001 'Supported EDI messages' is mapped to this position.

Processing incoming

EDI subsystem: This field is filled with the fixed value 'FAB-IO'.

BAAN: The message code in the table tcedi001 'Supported EDI Messages' determines, which internal message in BAAN is connected to this schedule. In the BAAN table tcedi005 'EDI Messages' is determined for every message which session (DLL ) is used in BAAN to process the shipping schedule. The message code is mapped to the BAAN table field tcedi702.mess.

Position	<b>6</b>	Field format	<b>an..6</b>	Field status	<b>M</b>
Field name	<b>Organization</b>				

Description: This field contains the organization (Standard) which is used for the EDI communication.

Processing outgoing

EDI subsystem:

BAAN: The internal organization code tcedi003.code 'BEMIS' from the BAAN table tcedi003 'Organizations' is mapped to this position.

## Processing incoming

EDI subsystem: This field is filled with the fixed value 'BEMIS'.

BAAN: Mapping to BAAN table field tcedi702.orga.

The corresponding organization must have been entered into the BAAN table tcedi003.

Position	<b>7</b>	Field format	<b>an..35</b>	Field status	<b>M</b>
Field name	<b>Order type</b>				

Description: This field contains a code for the concerned order type.

## Processing outgoing

EDI subsystem:

BAAN: In the BAAN table tcedi011 there must be an entry for this order type in connection with the appropriate message and organization. The BAAN table field tcedi011.koor is mapped to this position. It is not filled at the moment.

## Processing incoming

EDI subsystem: This position is not filled at the moment.

BAAN: Mapping to BAAN table field tcedi702.koor.

In the BAAN table tcedi200 there must be an entry for this order type in connection with the appropriate message and organization.

Position	<b>8</b>	Field format	<b>an..20</b>	Field status	<b>M</b>
Field name	<b>Transmission Reference</b>				

Description: This field contains the reference code, which the EDI subsystem applied to this transmission.

## Processing outgoing

EDI subsystem: Entry of the reference code for the transmission into the transmission file.

BAAN: The position is filled with 0 .

## Processing incoming

EDI subsystem: Transmission of the value from the transmission file.

BAAN: Mapping to BAAN table field tcedi702.msno

Position	<b>9</b>	Field format	n..8	Field status	<b>M</b>
Field name	<b>Date of transmission</b>				

Description: This field contains on the outgoing side the date, on which the schedule message was created. On the incoming side, this field contains the arrival date of the schedule at the EDI subsystem (format: YYYYMMDD).

Processing outgoing

EDI subsystem:

BAAN: Mapping of the current date to the position.

Processing incoming

EDI subsystem: Entry of the arrival date of the message at the EDI subsystem.

BAAN: Mapping to BAAN table field tcedi702.send

Position	<b>10</b>	Field format	n..4	Field status	<b>M</b>
Field name	<b>Time of transmission</b>				

Description: This field contains on the outgoing side the time, when the schedule message was created. On the incoming side, the field contains the arrival time of the schedule at the EDI subsystem (format: HHMM).

Processing outgoing

EDI subsystem:

BAAN: Mapping of the current time to the position.

Processing incoming

EDI subsystem: Entry of the arrival time of the message at the EDI subsystem.

BAAN: Mapping to BAAN table field tcedi702.send.



Position	<b>11</b>	Field format	<b>an..20</b>	Field status	<b>M</b>
Field name	<b>Transmission reference old</b>				

Description: This field contains the reference number, which the EDI subsystem applied to the previous transmission.

Processing outgoing

EDI subsystem: Entry of the reference code for the previous transmission into the transmission file.

BAAN: The position is filled with 0.

Processing incoming

EDI subsystem: Transmission of the value from the transmission file.

BAAN: Mapping to BAAN table field tcedi702.prho

Position	<b>12</b>	Field format	<b>an7</b>	Field status	<b>M</b>
Field name	<b>End of record marker</b>				

Description: The field indicates the end of the record. It contains the fixed value 'SA1\_END'.

Processing outgoing

EDI subsystem:

BAAN: The field is filled with the fixed value 'SA1\_END'.

Processing incoming

EDI subsystem: The field is filled with the fixed value 'SA1\_END'.

BAAN: None

## SA2 Shipping Schedule Header

Status :	Mandatory
Frequency:	Once by item number
Description:	This kind of data record is used to transmit item specific data. The data record contains information about the previous schedule, the exact delivery address and information about schedule authorizations. All data records up to the next data record of the type SA2 refer to the same item number.

SHIPPING SCHEDULE INHOUSE FORMAT					Mapping from Application Table Fields (out)		Mapping to Application Fields (in)	
Pos	FIELD DESCRIPTION	Key	ST	FM	Table Field	Action	Table Field	Action
1	Record type	O/I	M	an3	SA2		SA2	
2	Message reference	O/I	M	an..14	tcedi701.bano		tcedi702.bano	
3	Supplier code (out)	O	M	an..6	tdpsc029.suno			Conversion (see below)
	Network address customer (in)	I	M	an..17			tcedi702.reno	
4	Code delivery address	O/I	M	an..20	tdpsc004.plnt (filled with tdpsc001.plnt & “ “ & tdpsc001.delp )		tdssc229.cdel	Generation by EDI subsystem Conversion based on qualifier in pos. 6 and 7 (see below)
5	Customer's item number	O/I	M	an..35	tdpsc029.item		tdssc229.item	Conversion based on qualifier in pos. 8 (see below)
6	Qualifier address code		M	an2	DP, here (...,"DP",...)		DP	
7	Qualifier address type		M	an2	ZZ, here (...,"ZZ",...)		ZZ	
8	Qualifier item number		M	an2	SA, here (...,"SA",...)		SA	
9	Customer's item number		M	an..35	tdpsc029.item		tdssc229.cпно	Key for search of contract.
10	Supplier's item number		CK	an..35	tdpsc029.cпно		tdssc229.txta	
11	Supplier's customer number		M	an..35	tccom020.ocus			
12	Customer's plant number		M	an..35	tdpsc001.plnt		tdssc229.plnt	Key for search for contract.
13	Final delivery point		M	an..32	tdpsc001.delp		tdssc229.delp	

SHIPPING SCHEDULE INHOUSE FORMAT					Mapping from Application Table Fields (out)		Mapping to Application Fields (in)	
Pos	FIELD DESCRIPTION	Key	ST	FM	Table Field	Action	Table Field	Action
14	Storage location (customer)		C	an..14	tdpsc001.cwar	In addition to final delivery point	tdssc229.cdoc	In addition to final delivery point
15	Line feed location		C	an..14	tdpsc001.lnfd		tdssc229.lnfd	
16	Shipping schedule number new		M	n..9	tdpsc029.dcin		tdssc229.scnn	
17	Shipping schedule date new		M	n..8	tdpsc029.isdt		tdssc229.isdt	
18	Use code		M	an1	tdpsc029.appc	Check of value range	tdssc229.appc	Check of value range
19	Signal critical stock level code		C	an1	Blank		tdssc229.txta	Check of value range
20	End date FAB time fence		C	n..8	Empty		tdssc229.txta	
21	Shipping schedule date type		M	an1	tdpsc001.deco	Check of value range	tdssc229.tdat	Check of value range
22	Order number		C	an..17	tdpsc029.cono		tdssc229.cono	
23	Discrepancy of cumulative		C	n..15	Empty		tdssc229.dcdf	Field format!
24	Actual cumulative quantity		M	n..10	tdpsc029.recq		tdssc229.intc	
25	Last transaction date		M	n..8	tdpsc007.date		tdssc229.dtbk	
26	Shipping note number last receipt		M	an..9	tdpsc007.dino		tdssc229.ides	
27	Shipping note date last receipt		M	n..8	tdpsc007.didt		tdssc229.ldat	
28	Shipping note quantity last receipt		M	n..9	tdpsc007.rqty		tdssc229.rcqt	
29	Status last receipt		M	an1	l	Check of value range	tdssc229.skey	Check of value range
30	Transaction date second last receipt		C	n..8	Empty		tdssc229.txta	
31	Shipping note number second last receipt		C	an..9	tdpsc007.dino		tdssc229.txta	

SHIPPING SCHEDULE INHOUSE FORMAT					Mapping from Application Table Fields (out)		Mapping to Application Fields (in)	
Pos	FIELD DESCRIPTION	Key	ST	FM	Table Field	Action	Table Field	Action
32	Shipping note date second last receipt		C	n..8	tdpsc007.didt		tdssc229.txta	
33	Shipping note quantity second last receipt		C	n..9	tdpsc007.rqty		tdssc229.txta	
34	Status second last receipt		C	an1		Check of value range	tdssc229.txta	Check of value range
35	Transaction date third last receipt		C	n..8	Empty		tdssc229.txta	
36	Shipping note number third last receipt		C	an..9	tdpsc007.dino		tdssc229.txta	
37	Shipping note date third last receipt		C	n..8	tdpsc007.didt		tdssc229.txta	
38	Shipping note quantity third last receipt		C	n..9	tdpsc007.rqty		tdssc229.txta	
39	Status third last receipt		C	an1		Check of value range	tdssc229.txta	Check of value range
40	Additional supplier		C	an..35		Text string	tdssc229.txta	
41	Additional item number		C	an..35		Text string	tdssc229.txta	
42	Actual cumulative quantity received		C	n..10	tdpsc001.cbar		tdssc229.iedi	
43	Date of annual reset (cums)		M	n..8	tdpsc001.rdat		tdssc229.iedi	
44	Cumulated quantity required (MGO)		C	n..12			tdssc229.creq	
45	Date of cumulated quantity required (MGO)		C	n..8			tdssc229.dtbk	
46	Purpose		C	an1	empty (...;...)		tdssc229.pups	
47	Horizon Start Date		C	n..8	empty (...;...)		tdssc229.hdtf	
48	Horizon End Date		C	n..8	empty (...;...)		tdssc229.hdtt	
49	End of record marker		M	an7	SA2_END		SA2_END	

### Detailed description

Position	<b>1</b>	Field format	<b>an3</b>	Field status	<b>M</b>
Field name	<b>Record type</b>			(Key field out/in)	

Description: This field identifies the kind of data record in the message block. It contains the fixed value 'SA2'.

Processing outgoing

EDI subsystem:

BAAN: This field is filled with the fixed value 'SA2'.

Processing incoming

EDI subsystem: This field is filled with the fixed value 'SA2'.

BAAN:

Position	<b>2</b>	Field format	<b>an..14</b>	Field status	<b>M</b>
Field name	<b>Message reference</b>			(Key field out/in)	

Description: This field identifies all connected data records of one shipping schedule. The numbering, which has to be unique by shipping schedule, helps to control the chronological order of the schedules and the complete transmission.

Processing outgoing

EDI subsystem:

BAAN: Refer to record type SA1.

Processing incoming

EDI subsystem: Refer to record type SA1.

BAAN:

Position	<b>3 out</b>	Field format	<b>an..6</b>	Field status	<b>M</b>
Field name	<b>Supplier code</b>			(Key field out)	

Description: This field contains the identification code, which the customer applied to the supplier.

Processing outgoing

EDI subsystem:

BAAN: Mapping of BAAN table field tdpssc029.suno to position.

Position	<b>3 in</b>	Field format	<b>an..17</b>	Field status	<b>M</b>
Field name	<b>Network address customer</b>			(Key field in)	

Description: This field contains the network address of the customer.

Processing incoming

EDI subsystem: Transmission of the value from the message file.

BAAN: The network address determines in the table tcedi028 'Relations by network' the corresponding business partner and network. The business partner identification is mapped to the BAAN table field tcedi702.reno.

Position	<b>4</b>	Field format	<b>an..20</b>	Field status	<b>M</b>
Field name	<b>Code delivery address</b>			(Key field out/in)	

Description: This field contains the code for the delivery address of the customer. The field consists of the *Plant* Code and the Code used for the *Final delivery point*. This position contains at maximum 20 characters.

Processing outgoing

EDI subsystem:

BAAN: Mapping of tdpssc004.plnt to position.  
BAAN generates this key on the basis of the data in tdpssc001.plnt and tdpssc001.delp. The length of this position is not fix. At first the BAAN System writes the data of tdpssc001.plnt to the position followed by a blank. After that the data of tdpssc001.delp is added.

Example for possible formats of this position:

Position																			
1	2	3	4	5	6	7	8	9	10	11	12	13	14	15	16	17	18	19	20
P	P	P		D	D	D	D	D	D										
P	P	P	P	P	P		D	D	D	D	D	D	D	D	D	D	D	D	



Blank



unused Position

Result in the message:

...;"PPP DDDDDD";...

...;"PPPPPP DDDDDDDDDDD";

P means code for plant D means code for delivery point

Mapping of the generated value to position.

Processing incoming

EDI subsystem: The EDI subsystem generates this key on the basis of the data in *Plant number Customer* and *Final delivery point*.

The format of this position should be the same as above.

BAAN: The conversion tables for the address codes can be found in the BAAN table *tcedi310* under the business partner and the *Organization* from data record SA1 and the *Address code-ID* from data record SA2. The BAAN internal address code of the generated *Code delivery address* is determined in this BAAN table and mapped to the BAAN table field *tdssc002.cdel*.

Position	<b>5</b>	Field format	<b>an..35</b>	Field status	<b>M</b>
Field name	<b>Customer's Item Number</b>		(Key field out/in)		

Description: This field contains the identification, which the customer applied to the required item.

Processing outgoing



EDI subsystem:

BAAN: Mapping of BAAN field tdpssc002.item to position

Processing incoming

EDI subsystem:

BAAN: The conversion tables for the item numbers can be found in the BAAN table tcedi306 under the business partner and the *Organization* from data record SA1 and the *Item group-ID* from data record SA2. The BAAN internal item number of the transmitted *Customer's item number* is determined in this BAAN table and mapped to the BAAN table field tdssc002.item.

Position	<b>6</b>	Field format	<b>an2</b>	Field status	<b>M</b>
Field name	<b>Qualifier Address Code</b>				

Description: This field contains the qualifier address code, which is used to determine the delivery address from the value in position 4. This position must be filled with the fixed value 'DP'.

Processing outgoing

EDI subsystem:

BAAN: This field is filled with the fixed value 'DP'.

Processing incoming

EDI subsystem: This field is filled with the fixed value 'DP'.

BAAN: The qualifier must be entered in the BAAN table tcedi218 (Address code IDs). It is taken into account when the BAAN internal delivery address code is determined from the value in position 4.

Position	<b>7</b>	Field format	<b>an2</b>	Field status	<b>M</b>
Field name	<b>Qualifier Address Type</b>				

Description: This field contains the qualifier address type, which is used to determine the delivery address from the value in position 4. This position must be filled with the fixed value 'ZZ'.

Processing outgoing

EDI subsystem:

BAAN: This field is filled with the fixed value 'ZZ'.

Processing incoming

EDI subsystem: This field is filled with the fixed value 'ZZ'.

BAAN: The qualifier must be entered in the BAAN table tcedi224 (Address types). It is taken into account when the BAAN internal delivery address code is determined from the value in position 4.

Position	<b>8</b>	Field format	<b>an2</b>	Field status	<b>M</b>
Field name	<b>Qualifier Item Number</b>				

Description: This field contains the qualifier, which is used to determine the item number from the *Customer's item number* in position 5. This position must be filled with the constant value 'SA' ('SA' = supplier's item number).

Processing outgoing

EDI subsystem:

BAAN: This field is filled with the fixed value 'SA'.

Processing incoming

EDI subsystem: This field is filled with the fixed value 'SA'.

BAAN: The qualifier must have been entered in the BAAN table tcedi232 (Item number IDs). It is taken into account when the BAAN internal item number is determined from the customer's item number in position 5.

Position	<b>9</b>	Field format	<b>an..35</b>	Field status	<b>M</b>
Field name	<b>Customer's Item Number</b>				

Description: This field contains the code for the customer's item number.

Processing outgoing

EDI subsystem:

BAAN: Mapping of BAAN field tdpsc029.item to position.

Processing incoming

EDI subsystem: Transmission of value from transmission file.

BAAN: Mapping to BAAN table field tdsse229.cpno.

Position	<b>10</b>	Field format	<b>an..35</b>	Field status	<b>C</b>
Field name	<b>Supplier's item number</b>				

Description: This field contains the identification, which the supplier applied to the required item.

Processing outgoing

EDI subsystem:

BAAN: Mapping of BAAN table field tdpsc029.cpdo to position.

Processing incoming

EDI subsystem: Transmission of value from transmission file.

BAAN: Mapping to BAAN table field tdssc229.txta.

Position	<b>11</b>	Field format	<b>an..35</b>	Field status	<b>M</b>
Field name	<b>Supplier's customer number</b>				

Description: This field contains the identification, which the supplier applies to the customer.

Processing outgoing

EDI subsystem:

BAAN: Mapping of BAAN table field tcom020.ocus to position.

Processing incoming

EDI subsystem:

BAAN: No processing

Position	<b>12</b>	Field format	<b>an..35</b>	Field status	<b>M</b>
Field name	<b>Customer's Plant Number</b>				

Description: This field contains the key for the plant of the customer, to which the goods have to be delivered.

Processing outgoing

EDI subsystem:

BAAN: Mapping of BAAN table field tdpsc001.plnt to position.

Processing incoming

EDI subsystem: The EDI subsystem uses this field to generate the *code delivery address*.

Transmission of the value from the transmission file.

BAAN: Mapping to BAAN table field tdssc002.plnt.

Position	<b>13</b>	Field format	<b>an..32</b>	Field status	<b>M</b>
Field name	<b>Final Delivery Point</b>				

Description: This field contains the customer identification for the final delivery point at the plant of the customer, to which the goods have to be delivered.

Processing outgoing

EDI subsystem:

BAAN: Mapping of BAAN table field tdpsc001.delp to position.

Processing incoming

EDI subsystem: The EDI subsystem uses this field to generate the *code delivery address*.

Transmission of the value from the transmission file.

BAAN: Mapping to BAAN table field tdssc002.delp.

Position	<b>14</b>	Field format	<b>an..14</b>	Field status	<b>C</b>
Field name	<b>Storage location (customer)</b>				

Description: This field contains the storage location of the customer as additional information for the *final delivery point*.

Processing outgoing

EDI subsystem:

BAAN: Mapping of BAAN table field tdpsc001.cwar to position.

Processing incoming

EDI subsystem: Transmission of the value from the transmission file.

BAAN: Mapping to BAAN table field tdssc002.cdoc

Position	<b>15</b>	Field format	<b>an..14</b>	Field status	<b>C</b>
Field name	<b>Line feed location</b>				

Description: This field contains the customer's identification of the location where the required material is consumed.

Processing outgoing

EDI subsystem:

BAAN: Mapping of BAAN table field tdpsc001.lnfd to position.

Processing incoming

EDI subsystem: Transmission of value from transmission file.

BAAN: Mapping to BAAN table field tdssc229.lnfd

Position	<b>16</b>	Field format	<b>n..9</b>	Field status	<b>M</b>
Field name	<b>Shipping Schedule Number New</b>				

Description: The customer applies a new number to every shipping schedule to be able to identify them. This number is entered into this field.

Processing outgoing

EDI subsystem:

BAAN: Mapping of BAAN table field tdpsc002.scnn to position.

Processing incoming

EDI subsystem: Transmission of value from transmission file.

BAAN: Mapping to BAAN table field tdssc229.scnn.

Position	<b>17</b>	Field format	<b>n..8</b>	Field status	<b>M</b>
Field name	<b>Shipping Schedule Date New</b>				

Description: This field contains the date when the shipping schedule was created by the customer (format: YYYYMMDD).

Processing outgoing

BAAN:

EDI subsystem: Mapping of BAAN table field tdpsc029.isdt to position.

## Processing incoming

BAAN: Transmission of value from transmission file.

EDI subsystem: Mapping to BAAN table field tdscc229.isdt.

Position	18	Field format	an1	Field status	M
Field name	Use code				

Description: This field contains the encoded item status code/use code for the required item. The values of the VDA recommendation 4905 have to be used:

No information ( <i>Keine Angaben</i> )	Blank
Series ( <i>Serie</i> )	S
Substitute ( <i>Ersatz allgemein</i> )	E
Series and substitute ( <i>Serie und Ersatz</i> )	U
Trial ( <i>Versuch</i> )	V
Pilot ( <i>Pilot</i> )	P
Additional requirement ( <i>Zusatzbedarf</i> )	Z
First sample ( <i>Erstmuster</i> )	M
Sample ( <i>Muster</i> )	Y
Other ( <i>Sonstige</i> )	X

## Processing outgoing

BAAN: Mapping of BAAN table field tdpcc001.appc to position.

EDI subsystem: Using the ODETTE-Standard you might need to convert the values.

## Processing incoming

EDI subsystem: Transmission of value from transmission file.

Using the ODETTE-Standard you might need to convert the values.

BAAN: Mapping to BAAN table field tdscc229.appc.

Position	<b>19</b>	Field format	<b>an1</b>	Field status	<b>C</b>
Field name	<b>Signal Critical Stock Level</b>				

Description: This field indicates, if the stock level for the required item on customer side is critical or not. Valid values:  
 'C' = Critical  
 Blank = Not critical

Processing outgoing

EDI subsystem:

BAAN: Position is filled with blank.

Processing incoming

EDI subsystem: Transmission of value from transmission file.

BAAN: Mapping to BAAN table field tdssc229.txta.

Position	<b>20</b>	Field format	<b>n..8</b>	Field status	<b>C</b>
Field name	<b>End Date FAB time fence</b>				

Description: This field indicates, until which date the shipping schedule is valid (format: YYYYMMDD).

Processing outgoing

EDI subsystem:

BAAN: This field is not used at the moment.

Processing incoming

EDI subsystem: Transmission of value from transmission file.

BAAN: Mapping to BAAN table field tdssc229.txta

Position	<b>21</b>	Field format	<b>an1</b>	Field status	<b>M</b>
Field name	<b>Type of shipping schedule date</b>				

Description: This field contains the identification of the *Type of shipping schedule date* of the shipping schedule data in record type SA4. Valid values:  
 1 = Delivery At this date the required quantity has to be delivered at the customer's plant.  
 2 = Pick-up At this date the required quantity has to be ready for pick-up at the supplier's plant.

Processing outgoing

EDI subsystem:

BAAN: Mapping of BAAN table field tdpsc001.deco to position.  
 Used code and conversion table: tcedi484.

Processing incoming

EDI subsystem: The EDI subsystem sets the value on the basis of the data in the transmission file. If no value is transmitted, the system by default sets the value '1'.

BAAN: Mapping to BAAN table field tdssc002.tdat. Used code and conversion table: tcedi485.

Position	<b>22</b>	Field format	<b>an..17</b>	Field status	<b>C</b>
Field name	<b>Order number</b>				

Description: This field contains the identification, which the customer applies to an order or to a contract.

Processing outgoing

EDI subsystem:

BAAN: Mapping of BAAN table field tdpsc029.cono to position.

Processing incoming

EDI subsystem: Transmission of value from transmission file.

BAAN: Mapping to BAAN table field tdssc229.cono



Position	<b>23</b>	Field format	<b>n..15</b>	Field status	<b>C</b>
Field name	<b>Discrepancy of cumulative</b>				

Description: This field contains the discrepancy of actual cumulative quantity and required cumulative quantity on customer side.

Field Format: NNNNNNNNNN.NNNN or  
-NNNNNNNNN.NNNN

Processing outgoing

EDI subsystem:

BAAN: This position is not used at the moment.

Processing incoming

EDI subsystem: Transmission of value from transmission file.

BAAN: Mapping to BAAN table field tdssc229.dcdf. If the amount of the cumulative discrepancy is negative a minus sign has to be added to the value.

Position	<b>24</b>	Field format	<b>n..10</b>	Field status	<b>M</b>
Field name	<b>Actual cumulative quantity</b>				

Description: This field contains the actual cumulative quantity of this item, which includes all posted deliveries from the *date of annual reset (cums)* to schedule calculation date.

Processing outgoing

EDI subsystem:

BAAN: Mapping of BAAN table field tdpsc029.recq to position.

Processing incoming

EDI subsystem: Transmission of value from transmission file.

BAAN: Mapping to BAAN table field tdssc229.intc.

Position	<b>25</b>	Field format	<b>n..8</b>	Field status	<b>M</b>
Field name	<b>Last transaction date</b>				

Description: The customer has booked all deliveries up to this date and taken them into account in his disposition (format: YYYYMMDD).

Processing outgoing

EDI subsystem:

BAAN: Mapping of BAAN table field tdpsc007.date to position.

Processing incoming

EDI subsystem: Transmission of value from transmission file.

BAAN: Mapping to BAAN table field tdssc229.dtbk.

Position	<b>26</b>	Field format	<b>n..6</b>	Field status	<b>M</b>
Field name	<b>Shipping note number last receipt</b>				

Description: This field contains the shipping note number of the last delivery for this item, which the customer received and posted.

Processing outgoing

EDI subsystem:

BAAN: Mapping of BAAN table field tdpsc007.dino to position.

Processing incoming

EDI subsystem: Transmission of value from transmission file.

BAAN: Mapping to BAAN table field tdssc229.ides.

Position	<b>27</b>	Field format	<b>n..8</b>	Field status	<b>M</b>
Field name	<b>Shipping note date last receipt</b>				

Description: This field contains the shipping note date of the last delivery for this item, which the customer received and posted (format: YYYYMMDD).

Processing outgoing

EDI subsystem:

BAAN: Mapping of BAAN table field tdpsc007.didt to position.

Processing incoming

EDI subsystem: Transmission of value from transmission file.

BAAN: Mapping to BAAN table field tdscc229.ldat.

Position	<b>28</b>	Field format	<b>n..9</b>	Field status	<b>M</b>
Field name	<b>Shipping note quantity last receipt</b>				

Description: This field contains the shipping note quantity of the last delivery for this item, which the customer received and posted.

Processing outgoing

EDI subsystem:

BAAN: Mapping of BAAN table field tdpcc007.rqty to position.

Processing incoming

EDI subsystem: Transmission of value from transmission file.

BAAN: Mapping to BAAN table field tdscc229.rcqt.

Position	<b>29</b>	Field format	<b>an1</b>	Field status	<b>M</b>
Field name	<b>Status last receipt</b>				

Description: This field contains the status of the last delivery. Valid values:  
 'I' = The customer posted the transaction (actual).  
 'P' = The customer has not posted the transaction yet. In this case, the transaction date is equal to the planned arrival date (planned).

Processing outgoing

EDI subsystem:

BAAN: This position is filled with the value 'I'.

Processing incoming

EDI subsystem: Transmission of value from transmission file.

BAAN: Mapping to BAAN table field tdscc229.skey.

Position	<b>30</b>	Field format	<b>n..8</b>	Field status	<b>C</b>
Field name	<b>Transaction date second last receipt</b>				

Description: This field contains the transaction date of the second last receipt for this item (format: YYYYMMDD).

Processing outgoing

EDI subsystem:

BAAN: This field is not used at the moment.

Processing incoming

EDI subsystem: Transmission of value from transmission file.

BAAN: Mapping to BAAN table field tdssc229.txta.

Position	<b>31</b>	Field format	<b>n..6</b>	Field status	<b>C</b>
Field name	<b>Shipping note number second last receipt</b>				

Description: This field contains the shipping note number of the second last receipt for this item, which the customer received and posted.

Processing outgoing

EDI subsystem:

BAAN: Mapping of BAAN table field tdpssc007.dino to position.

Processing incoming

EDI subsystem: Transmission of value from transmission file.

BAAN: Mapping to BAAN table field tdssc229.txta.

Position	<b>32</b>	Field format	<b>n..8</b>	Field status	<b>C</b>
Field name	<b>Shipping note date second last receipt</b>				

Description: This field contains the delivery date of the second last delivery for this item, which the customer received and posted (format: YYYYMMDD).

Processing outgoing

EDI subsystem:

BAAN: Mapping of BAAN table field tdpssc007.didt to position.

Processing incoming

EDI subsystem: Transmission of value from transmission file.

BAAN: Mapping to BAAN table field tdssc229.txta.

Position	<b>33</b>	Field format	<b>n..9</b>	Field status	<b>C</b>
Field name	<b>Shipping note quantity second last receipt</b>				

Description: This field contains the shipping note quantity of the second last delivery for this item, which the customer received and posted.

Processing outgoing

EDI subsystem:

BAAN: Mapping of BAAN table field tdpssc007.rqty to position.

Processing incoming

EDI subsystem: Transmission of value from transmission file.

BAAN: Mapping to BAAN table field tdssc229.txta

Position	<b>34</b>	Field format	<b>an1</b>	Field status	<b>C</b>
Field name	<b>Status second last receipt</b>				

Description: This field contains the status of the second last delivery.  
Valid values:  
'I' = The customer posted the transaction (actual).  
'P' = The customer has not posted the transaction yet. In this case, the transaction date equals the planned arrival date (planned).

Processing outgoing

EDI subsystem:

BAAN: This position is filled with the value 'I'.

Processing incoming

EDI subsystem: Transmission of value from transmission file.

BAAN: Mapping to BAAN table field tdssc229.txta.

Position	<b>35</b>	Field format	<b>n..8</b>	Field status	<b>C</b>
Field name	<b>Transaction date third last receipt</b>				

Description: This field contains the transaction date of the third last receipt for this item (format: YYYYMMDD).

Processing outgoing

EDI subsystem:

BAAN: This field is not used at the moment.

Processing incoming

EDI subsystem: Transmission of value from transmission file.

BAAN: Mapping to BAAN table field tdssc229.txta.

Position	<b>36</b>	Field format	<b>n..6</b>	Field status	<b>C</b>
Field name	<b>Shipping note number third last receipt</b>				

Description: This field contains the shipping note number of the third last delivery for this item, which the customer received and posted.

Processing outgoing

EDI subsystem:

BAAN: Mapping of BAAN table field tdpsc007.dino to position.

Processing incoming

EDI subsystem: Transmission of value from transmission file.

BAAN: Mapping to BAAN table field tdssc229.txta.

Position	<b>37</b>	Field format	<b>n..8</b>	Field status	<b>C</b>
Field name	<b>Shipping note date third last receipt</b>				

Description: This field contains the shipping note date of the last delivery for this item, which the customer received and posted (format: YYYYMMDD).

Processing outgoing

EDI subsystem:

BAAN: Mapping of BAAN table field tdpsc007.didt to position.

Processing incoming

EDI subsystem: Transmission of value from transmission file.

BAAN: Mapping to BAAN table field tdssc229.txta.

Position	<b>38</b>	Field format	<b>n..9</b>	Field status	<b>C</b>
Field name	<b>Shipping note quantity third last receipt</b>				

Description: This field contains the shipping note quantity of the third last delivery for this item, which the customer received and posted

Processing outgoing

EDI subsystem:

BAAN: Mapping of BAAN table field tdpssc007.rqty to position.

Processing incoming

EDI subsystem: Transmission of value from transmission file.

BAAN: Mapping to BAAN table field tdssc229.txta.

Position	<b>39</b>	Field format	<b>an1</b>	Field status	<b>C</b>
Field name	<b>Status third last receipt</b>				

Description: This field contains the status of the third last delivery. Valid values:  
 'I' = The customer posted the transaction (actual).  
 'P' = The customer has not yet posted the transaction. In this case, the transaction date is equal to the planned arrival date (planned).

Processing outgoing

EDI subsystem:

BAAN: The position is filled with the value 'I'.

Processing incoming

EDI subsystem: Transmission of value from transmission file.

BAAN: Mapping to BAAN table field tdssc229.txta.

Position	<b>40</b>	Field format	<b>an..40</b>	Field status	<b>C</b>
Field name	<b>Additional supplier</b>				

Description: This field contains the identification, which the customer applied to an additional supplier.

Processing outgoing

EDI subsystem:

BAAN: The position is filled with a text string.

Processing incoming

EDI subsystem: Transmission of value from transmission file.

BAAN: Mapping to BAAN table field tdssc229.txta.

Position	<b>41</b>	Field format	<b>an..40</b>	Field status	<b>C</b>
Field name	<b>Additional item number</b>				

Description: This field contains the additional item number, which the customer applied to this item.

Processing outgoing

EDI subsystem:

BAAN: This position is filled with a text string.

Processing incoming

EDI subsystem: Transmission of value from transmission file.

BAAN: Mapping to BAAN table field tdssc229.txta.

Position	<b>42</b>	Field format	<b>n..10</b>	Field status	<b>C</b>
Field name	<b>Actual cumulative quantity received</b>				

Description: This field contains the actual cumulative quantity of this item prior to the last reset.

Processing outgoing

EDI subsystem:

BAAN: Mapping of BAAN table field tdpssc001.cbar to position.



Processing incoming

EDI subsystem: Transmission of value from transmission file.

BAAN: Mapping to BAAN table field tdssc229.iedi.

Position	<b>43</b>	Field format	<b>n..8</b>	Field status	<b>M</b>
Field name	<b>Date of annual reset (cums)</b>				

Description: This field contains the latest date, at which the actual cumulative quantity of that item was reset to zero format: YYYYMMDD).

Processing outgoing

EDI subsystem:

BAAN: Mapping of BAAN table field tdpssc001.rdat to position.

Processing incoming

EDI subsystem: Transmission of value from transmission file.

BAAN: Mapping to BAAN table field tdssc229.iedi.

Position	<b>44</b>	Field format	<b>n..12</b>	Field status	<b>C</b>
Field name	<b>Cumulated quantity required (MGO)</b>				

Description: This field contains the cumulated required quantity sent by the customer .

Processing outgoing

EDI subsystem:

BAAN: None

Processing incoming

EDI subsystem: Transmission of the value from the transmission file.

BAAN: Mapping to BAAN table field tdssc229.creq

Position	<b>45</b>	Field format	n..8	Field status	<b>C</b>
Field name	<b>Date of Cumulated quantity required (MGO)</b>				

Description: This field contains the date related to the cumulated required quantity sent by the customer (format: YYYYMMDD).

Processing outgoing

EDI subsystem:

BAAN: None

Processing incoming

EDI subsystem: Transmission of the value from the transmission file.

BAAN: Mapping to BAAN table field tdssc229.dtbk

Position	<b>46</b>	Field format	an1	Field status	<b>C</b>
Field name	<b>Purpose</b>				

Description: This field identifies the kind of schedule  
 1 = Replacement  
 2 = Replacement between Dates  
 3 = Change

Processing outgoing

EDI subsystem:

BAAN: None

Processing incoming

EDI subsystem: The EDI subsystem fills the field based on the information in the transmission file.

BAAN: Mapping to BAAN table field tdssc229.pups by use of Conversion Table tcedi488 (Conversion of Purpose Code (In))

Position	<b>47</b>	Field format	n..8	Field status	<b>C</b>
Field name	<b>Horizon Start Date</b>				

Description: This field contains the 'From Date' in case of a 'Replacement between Dates' schedule  
(format: YYYYMMDD)

Processing outgoing

EDI subsystem:

BAAN: None

Processing incoming

EDI subsystem: Transmission of the value from the transmission file.

BAAN: Mapping to BAAN table field tdssc229.hdtf

Position	<b>48</b>	Field format	n..8	Field status	<b>C</b>
Field name	<b>Horizon End Date</b>				

Description: This field contains the 'To Date' in case of a 'Replacement between Dates' schedule  
(format: YYYYMMDD)

Processing outgoing

EDI subsystem:

BAAN: None

Processing incoming

EDI subsystem: Transmission of the value from the transmission file.

BAAN: Mapping to BAAN table field tdssc229.hdtf

Position	<b>49</b>	Field format	<b>an7</b>	Field status	<b>M</b>
Field name	<b>End of record marker</b>				

Description: The field indicates the end of the record. It contains the fixed value 'SA2\_END'.

Processing outgoing

EDI subsystem:

BAAN: The field is filled with the fixed value 'SA2\_END'.

Processing incoming

EDI subsystem: The field is filled with the fixed value 'SA2\_END'.

BAAN: None

## SA3 Shipping Schedule Text

Status : Conditional

Frequency : Repeatable by item number

Description: This data record supports the transmission of shipping schedule instructions for the supplier. These instructions are applied to the appropriate item, which is indicated in the previous data record SA2.

SHIPPING SCHEDULE INHOUSE FORMAT					Mapping from Application Table Fields (out)		Mapping to Application Fields (in)	
Pos	FIELD DESCRIPTION	Key	ST	FM	Table Field	Action	Table Field	Action
1	Record type	O/I	M	an3	SA3		SA3	
2	Message reference	O/I	M	an..14	tcedi701.bano		tcedi702.bano	
3	Supplier number (out)	O	M	an..6	tdpsc029.suno			
	Network address customer (in)	I	M	an..17			cedi702.reno	
4	Code delivery address	O/I	M	an..20	tdpsc001.plnt + tdpsc001.delp		tdssc229.cdel	
5	Customer's item code	O/I	M	an..35	tdpsc029.item		tdssc229.item	
6	Shipping Schedule Text 1		M	an..70	tdpsc029.txta		tdssc229.txta	
7	Shipping Schedule Text 2		C	an..70	tdpsc029.txta		tdssc229.txta	
8	Shipping Schedule Text 3		C	an..70	tdpsc029.txta		tdssc229.txta	
9	End of record marker		M	an7	SA3_END		SA3_END	

## Detailed description

Position	<b>1</b>	Field format	<b>an3</b>	Field status	<b>M</b>
Field name	<b>Record type</b>		(Key field)		

Description: This field identifies the record type in the message block. It contains the fixed value 'SA3'.

Processing outgoing

EDI subsystem:

BAAN: This field is filled with the fixed value 'SA3'.

Processing incoming

EDI subsystem: This field is filled with the fixed value 'SA3'.

BAAN: None

Position	<b>2</b>	Field format	<b>an..14</b>	Field status	<b>M</b>
Field name	<b>Message reference</b>		(Key field)		

Description: This field identifies all connected data records of one shipping schedule. The numbering, which has to be unique by shipping schedule, helps to control the chronological order of the schedules and the complete transmission.

Processing outgoing

EDI subsystem:

BAAN: Refer to record type SA2.

Processing incoming

EDI subsystem: Refer to record type SA2.

BAAN: Refer to record type SA2.

Position	<b>3 out</b>	Field format	<b>an..6</b>	Field status	<b>M</b>
Field name	<b>Supplier number</b>		(Key field)		

Description: This field contains the identification the customer applied to the supplier.

Processing outgoing

EDI subsystem:

BAAN: Refer to record type SA2.

Position	<b>3 in</b>	Field format	<b>an..17</b>	Field status	<b>M</b>
Field name	<b>Network address customer</b>		(Key field)		

Description: This field contains the network address of the customer.

Processing incoming

EDI subsystem: Refer to record type SA2.

BAAN: Refer to record type SA2.

Position	<b>4</b>	Field format	<b>an..20</b>	Field status	<b>M</b>
Field name	<b>Code delivery address</b>		(Key field)		

Description: This field contains the code for the delivery address of the customer.

Processing outgoing

EDI subsystem:

BAAN: Refer to record type SA2.

Processing incoming

EDI subsystem: Refer to record type SA2.

BAAN: Refer to record type SA2.

Position	<b>5</b>	Field format	<b>an..35</b>	Field status	<b>M</b>
Field name	<b>Customer's item number</b>				

Description: This field contains the identification, which the customer applied to the required item.

Processing outgoing

EDI subsystem:

BAAN: Refer to record type SA2.

Processing incoming

EDI subsystem: Refer to record type SA2.

BAAN: Refer to record type SA2.

Position	<b>6</b>	Field format	<b>an..70</b>	Field status	<b>M</b>
Field name	<b>Shipping schedule text 1</b>				

Description: This field contains a shipping schedule text with 70 characters.

Processing outgoing

EDI subsystem:

BAAN: Mapping of BAAN table field tdpsc029.txta to position.

Processing incoming

EDI subsystem: Transmission of value from transmission file.

BAAN: Mapping to BAAN table field tdssc229.txta.

Position	<b>7</b>	Field format	<b>an..70</b>	Field status	<b>C</b>
Field name	<b>Shipping schedule text 2</b>				

Description: This field contains a shipping schedule text with 70 characters.

Processing outgoing

EDI subsystem:

BAAN: Mapping of BAAN table field tdpsc029.txta to position.

Processing incoming

EDI subsystem: Transmission of value from transmission file.

BAAN: Mapping to BAAN table field tdssc229.txta.



Position	<b>8</b>	Field format	<b>an..70</b>	Field status	<b>C</b>
Field name	<b>Shipping schedule text 3</b>				

Description: This field contains a shipping schedule text with 70 characters.

Processing outgoing

EDI subsystem:

BAAN: Mapping of BAAN table field tdpsc029.txta to position

Processing incoming

EDI subsystem: Transmission of value from transmission file.

BAAN: Mapping to BAAN table field tdssc229.txta.

Position	<b>9</b>	Field format	<b>an7</b>	Field status	<b>M</b>
Field name	<b>End of record marker</b>				

Description: The field indicates the end of the record. It contains the fixed value 'SA3\_END'.

Processing outgoing

EDI subsystem:

BAAN: The field is filled with the fixed value 'SA3\_END'.

Processing incoming

EDI subsystem: The field is filled with the fixed value 'SA3\_END'.

BAAN: None

## SA4 Shipping Schedule Lines

Status : Mandatory

Frequency: Repeatable by item number

Description: This record type supports the transfer of the required item quantity, which is indicated in the data record SA2.  
The customer determines the quantities, which are required at certain dates.

SHIPPING SCHEDULE INHOUSE FORMAT					Mapping from Application Table Fields (out)		Mapping to Application Fields (in)	
Pos	FIELD DESCRIPTION	Key	ST	FM	Table Field	Action	Table Field	Action
1	Record type	O/I	M	an3	SA4		SA4	
2	Message reference	O/I	M	an..14	tcedi701.bano		tcedi702.bano	
3	Supplier number (out)	O	M	an..6	tdpsc001.suno			
	Network address customer (in)	I	M	an..17			tdssc229.cuno	
4	Code delivery address	O/I	M	an..20	tdpsc001.plnt + tdpsc001.delp		tdssc229.cdel	
5	Customer's item number	O/I	M	an..35	tdpsc029.item		tdssc229.item	
6	Shipping schedule date		M	n..8	tdpsc030.date		tdssc230.date	
7	Shipping schedule time		M	n..4	tdpsc030.time		tdssc230.time	
8	Shipping schedule quantity		M	n..9	tdpsc030.dciq		tdssc230.dciq	
9	Requirement status		C	an1	B or Blank			
10	RAN.- / DON – Number		C	an..12	Empty Position (...;..)		tdssc230.ican	
11	First Delivery Date		C	n..8	Empty Position (...;..)		tdssc230.fsdt	
12	First Delivery Time		C	n..4	Empty Position (...;..)		tdssc230.fsti	
13	Last Delivery Date		C	n..8	Empty Position (...;..)		tdssc230.lsd	
14	Last Delivery Time		C	n..4	Empty Position (...;..)		tdssc230.lsti	
15	End of record marker		M	an7	SA4_END		SA4_END	

**Detailed description**

Position	<b>1</b>	Field format	<b>an3</b>	Field status	<b>M</b>
Field name	<b>Record type</b>			(Key field)	

Description: This field identifies the kind of data record in the message block. It contains the fixed value 'SA4'.

Processing outgoing

EDI subsystem:

BAAN: This field is filled with the fixed value 'SA4'.

Processing incoming

EDI subsystem: This field is filled with the fixed value 'SA4'.

BAAN: None

Position	<b>2</b>	Field format	<b>an..14</b>	Field status	<b>M</b>
Field name	<b>Message reference</b>			(Key field)	

Description: This field identifies all connected data records of one shipping schedule. The numbering, which has to be unique by shipping schedule, helps to control the chronological order of the schedules and the complete transmission.

Processing outgoing

EDI subsystem:

BAAN: Refer to record type SA2.

Processing incoming

EDI subsystem: Refer to record type SA2.

BAAN: Refer to record type SA2.

Position	<b>3 out</b>	Field format	<b>an..6</b>	Field status	<b>M</b>
Field name	<b>Supplier number</b>			(Key field)	

Description: This field contains the identification, which the customer applied to the supplier.

Processing outgoing

EDI subsystem:

BAAN: Refer to record type SA2.

Position	<b>3 in</b>	Field format	<b>an..17</b>	Field status	<b>M</b>
Field name	<b>Network address customer</b>			(Key field)	

Description: This field contains the network address of the customer.

Processing incoming

EDI subsystem: Refer to record type SA2.

BAAN: Refer to record type SA2.

Position	<b>4</b>	Field format	<b>an..20</b>	Field status	<b>M</b>
Field name	<b>Code delivery address</b>			(Key field)	

Description: This field contains the code for the delivery address of the customer.

Processing outgoing

EDI subsystem:

BAAN: Refer to record type SA2.

Processing incoming

EDI subsystem: Refer to record type SA2.

BAAN: Refer to record type SA2.

Position	<b>5</b>	Field format	<b>an..35</b>	Field status	<b>M</b>
Field name	<b>Customer's item number</b>				

Description: This field contains the identification, which the customer applied to the required item.

Processing outgoing

EDI subsystem:

BAAN: Refer to record type SA2.

Processing incoming

EDI subsystem: Refer to record type SA2.

BAAN: Refer to record type SA2.

Position	<b>6</b>	Field format	<b>n..8</b>	Field status	<b>M</b>
Field name	<b>Shipping schedule date</b>				

Description: This field contains the date for the requirement of this schedule position. It needs to be interpreted on the basis of the *Shipping schedule date type* of record type 2.

Processing outgoing

EDI subsystem:

BAAN: Mapping of BAAN table field tdpsc030.date to position.

Processing incoming

EDI subsystem:

BAAN: Mapping to BAAN table field tdssc230.date.

Position	<b>7</b>	Field format	<b>n..4</b>	Field status	<b>M</b>
Field name	<b>Shipping schedule time</b>				

Description: This field contains the time for the requirement of this schedule position. It needs to be interpreted on the basis of the *Schedule date type* of the record type 2.

Processing outgoing

EDI subsystem:

BAAN: Mapping of BAAN table field tdpsc030.time to position.

Processing incoming

EDI subsystem:

BAAN: Mapping to BAAN table field tdssc230.time.

Position	<b>8</b>	Field format	<b>n..9</b>	Field status	<b>M</b>
Field name	<b>Shipping schedule quantity</b>				

Description: This field contains the quantity of this schedule position.

Processing outgoing

EDI subsystem:

BAAN: Mapping of BAAN table field tdpsc030.dciq to position.

Processing incoming

EDI subsystem: The EDI subsystem transfers the quantity of this schedule position to this field.

BAAN: Mapping to BAAN table field tdssc230.dciq.

Position	<b>9</b>	Field format	<b>an1</b>	Field status	<b>C</b>
Field name	<b>Requirement status</b>				

Description: The requirement status indicates, until which date the supplier should keep the FAB data of the previous shipping schedule.

The value "B" indicates that the supplier should overtake the FAB data of the previous transmission until this date without any change. Only one position of every shipping schedule should have the value "B". All other positions have to be filled with blanks.

Processing outgoing

EDI subsystem:

BAAN: This field is filled with a blank.

Processing incoming

EDI subsystem:

BAAN:

Position	<b>10</b>	Field format	<b>an..12</b>	Field status	<b>M</b>
Field name	<b>RAN - / DON Number</b>				

Description: This field contains the RAN - / DON Number..

Processing outgoing

EDI subsystem: None.

BAAN: None; empty Position (...;...)

Processing incoming

EDI subsystem: The EDI subsystem transfers the RAN - / DON - Number to this field.

BAAN: Mapping to BAAN table field tdssc230.ican

Position	<b>11</b>	Field format	<b>n..8</b>	Field status	<b>M</b>
Field name	<b>First Delivery Date</b>				

Description: This field contains the earliest date of delivery at the unloading point.

Processing outgoing

EDI subsystem:

BAAN: None; empty Position (...;...)

Processing incoming

EDI subsystem:

BAAN: Mapping to BAAN table field tdssc230.fsdt.

Position	<b>12</b>	Field format	<b>n..4</b>	Field status	<b>M</b>
Field name	<b>First Delivery Time</b>				

Description: This field contains the earliest time of delivery at the unloading point.

Processing outgoing

EDI subsystem:

BAAN: None; empty Position (...;...)

Processing incoming

EDI subsystem:

BAAN: Mapping to BAAN table field tdssc230.fsti.

Position	<b>13</b>	Field format	<b>n..8</b>	Field status	<b>M</b>
Field name	<b>Last Delivery Date</b>				

Description: This field contains the latest date of delivery at the unloading point.

Processing outgoing

EDI subsystem:

BAAN: None; empty Position (...;...)

Processing incoming

EDI subsystem:

BAAN: Mapping to BAAN table field tdssc230.lst.



Position	<b>14</b>	Field format	<b>n..4</b>	Field status	<b>M</b>
Field name	<b>Last Delivery Time</b>				

Description: This field contains the latest time of delivery at the unloading point.

Processing outgoing

EDI subsystem:

BAAN: None; empty Position (...;...)

Processing incoming

EDI subsystem:

BAAN: Mapping to BAAN table field tdssc230.lsti.

Position	<b>15</b>	Field format	<b>an7</b>	Field status	<b>M</b>
Field name	<b>End of record marker</b>				

Description: The field indicates the end of the record. It contains the fixed value 'SA4\_END'.

Processing outgoing

EDI subsystem:

BAAN: The field is filled with the fixed value 'SA4\_END'.

Processing incoming

EDI subsystem: The field is filled with the fixed value 'SA4\_END'.

BAAN: None

## SA5 Packaging Data

Status: Optional

Frequency: up to 4 times by item number outgoing  
up to n times by item number incoming

BAAN IV purchase contracts contain a 4 level packaging structure, which can be transmitted by SA6. The first level represents the outer packaging, the other levels represent intermediate packaging and smaller packagings (level 4).

Description: This record type supports the transmission of packaging information, which can be used for the required item of the previous record of the data record SA2 (item number, capacity): This kind of data record is repeatable if several packagings have to be used.

## 1 Packaging level (outgoing) - All packagings (incoming)

SHIPPING SCHEDULE INHOUSE FORMAT					Mapping from Application Table Fields (out)		Mapping to Application Fields (in)	
Pos	FIELD DESCRIPTION	Key	ST	FM	Table Field	Action	Table Field	Action
1	Record type	O/I	M	an3	SA5	Evaluation expression PI1	SA5	
2	Message reference	O/I	M	an..14	tcedi701.bano		tcedi702.bano	
3	Supplier number (out)	O	M	an..6	tdpsc001.suno			
	Network address customer (in)	I	M	an..17			cedi702.reno	
4	Code delivery address	O/I	M	an..20	tdpsc001.plnt + tdpsc001.delp		tdssc229.cdel	
5	Customer's item number	O/I	M	an..35	tdpsc029.item		tdssc229.item	
6	Customer's item number for packaging 1		M	an..35	tdpsc001.utyp	Evaluation expression PI1	tdssc231.cpak	
7	Supplier's item number for packaging 1		C	an..35	tdpsc001.utyp	Evaluation expression PI1	tdssc231.pack	
8	Quantity of items in package 1		M	n..9	tdpsc001.uqty	Evaluation expression PI1	tdssc231.cqty	
9	Flag 'Full packaging only 1'		M	n1	tdpsc001.uful	Evaluation expression PI1	Blank	
10	Qualifier for Item number		M	an2	SA	Evaluation expression PI1	SA	
11	Packaging Level		M	n1	3 or 1	Evaluation expression PI1/PI5	tdssc231.plvl	
12	Packaging Type		C	an1	M	Evaluation expression PI1	tdssc231.ptyp	
13	Number of Packages		M	n..4	empty	Evaluation expression PI1	tdssc231.puqt	
14	Sales Unit		C	an..3	tdpsc001.cuqp	Evaluation expression PI1	tdssc231.cuqs	Conversion
15	Package Description		C	an35	empty	Evaluation expression PI1	tdssc231.dsca	
16	Code List Agency		C	an..3	empty	Evaluation expression PI1	tdssc231.clra	
17	End of record marker		M	an7	SA5_END	Evaluation expression PI1	SA5_END	

## 2 Packaging level (outgoing)

SHIPPING SCHEDULE INHOUSE FORMAT					Mapping from Application Table Fields (out)	
Pos	FIELD DESCRIPTION	Key	ST	FM	Table Field	Action
1	Record type	O	M	an3	SA5	Evaluation expression PI2
2	Message reference	O	M	an..14	tcedi701.bano	
3	Supplier number (out)  Network address customer (in)	O	M	an..6	tdpsc001.suno	
4	Code delivery address	O	M	an..20	tdpsc001.plnt + tdpsc001.delp	
5	Customer's item number	O	M	an..35	tdpsc029.item	
6	Customer's item number for packaging 2		M	an..35	tdpsc001.mtyp	Evaluation expression PI2
7	Customer's item number for packaging 2		C	an..35	tdpsc001.mtyp	Evaluation expression PI2
8	Quantity of items in package 2		M	n..9	tdpsc001.mqty	Evaluation expression PI2
9	Flag 'Full packaging only 2'		M	n1	tdpsc001.mful	Evaluation expression PI2
10	Qualifier for Item number		M	an2	SA	Evaluation expression PI2
11	Packaging Level		M	n1	2	Evaluation expression PI2
12	Packaging Type		C	an1	A	Evaluation expression PI2
13	Number of Packages		M	n..4	empty	Evaluation expression PI2
14	Sales Unit		C	an..3	tdpsc001.cuqp	Evaluation expression PI2
15	Package Description		C	an35	empty	Evaluation expression PI2
16	Code List Agency		C	an..3	empty	Evaluation expression PI2
17	End of record marker		M	an7	SA5_END	Evaluation expression PI2

## 3 Packaging level (outgoing)

SHIPPING SCHEDULE INHOUSE FORMAT					Mapping from Application Table Fields (out)	
Pos	FIELD DESCRIPTION	Key	ST	FM	Table Field	Action
1	Record type	O	M	an3	SA5	Evaluation expression PI3
2	Message reference	O	M	an..14	tcedi701.bano	
3	Supplier number (out) Network address customer (in)	O	M	an..6	tdpsc001.suno	
4	Code delivery address	O	M	an..20	tdpsc001.plnt + tdpsc001.delp	
5	Customer's item number	O	M	an..35	tdpsc029.item	
6	Customer's item number for packaging 3		M	an..35	tdpsc001.btyp	Evaluation expression PI3
7	Customer's item number for packaging 3		C	an..35	tdpsc001.btyp	Evaluation expression PI3
8	Quantity of items in package 3		M	n..9	tdpsc001.bqty	Evaluation expression PI3
9	Flag 'Full packaging only 3'		M	n1	tdpsc001.bful	Evaluation expression PI3
10	Qualifier for Item number		M	an2	SA	Evaluation expression PI3
11	Packaging Level		M	n1	2	Evaluation expression PI3
12	Packaging Type		C	an1	A	Evaluation expression PI3
13	Number of Packages		M	n..4	empty	Evaluation expression PI3
14	Sales Unit		C	an..3	tdpsc001.cuqp	Evaluation expression PI3
15	Package Description		C	an35	empty	Evaluation expression PI3
16	Code List Agency		C	an..3	empty	Evaluation expression PI3
17	End of record marker		M	an7	SA5_END	Evaluation expression PI3

## 4 Packaging level (outgoing)

SHIPPING SCHEDULE INHOUSE FORMAT					Mapping from Application Table Fields (out)	
Pos	FIELD DESCRIPTION	Key	ST	FM	Table Field	Action
1	Record type	O	M	an3	SA5_END	Evaluation expression PI4
2	Message reference	O	M	an..14	tcedi701.bano	
3	Supplier number (out) Network address customer (in)	O	M	an..6	tdpsc001.suno	
4	Code delivery address	O	M	an..20	tdpsc001.plnt + tdpsc001.delp	
5	Customer's item number	O	M	an..35	tdpsc029.item	
6	Customer's item number for packaging 4		M	an..35	tdpsc001.atyp	Evaluation expression PI4
7	Customer's item number for packaging 4		C	an..35	tdpsc001.atyp	Evaluation expression PI4
8	Quantity of items in package 4		M	n..9	tdpsc001.aqty	Evaluation expression PI4
9	Flag 'Full packaging only 4'		M	n1	tdpsc001.aful	Evaluation expression PI4
10	Qualifier for Item number		M	an2	SA	Evaluation expression PI4
11	Packaging Level		M	n1	1	Evaluation expression PI4
12	Packaging Type		C	an1	M	Evaluation expression PI4
13	Number of Packages		C	n..4	empty	Evaluation expression PI4
14	Sales Unit		C	an..3	tdpsc001.cuqp	Evaluation expression PI4
15	Package Description		C	an35	empty	Evaluation expression PI4
16	Code List Agency		C	an..3	empty	Evaluation expression PI4
17	End of record marker		M	an7	SA5_END	Evaluation expression PI4

**Remark about evaluation expressions:**

The evaluation expressions indicate, if a special action needs to be carried out. In this case the evaluation expressions control, if a data record or certain field is written or not. They are only written, if the corresponding fields in BAAN are filled:

PI1	Packaging information level 1 available	tdpsc001.utyp > ' '
PI2	Packaging information level 2 available	tdpsc001.mtyp > ' '
PI3	Packaging information level 3 available	tdpsc001.btyp > ' '
PI4	Packaging information level 4 available	tdpsc001.atyp > ' '

**Detailed description**

Position	<b>1</b>	Field format	<b>an3</b>	Field status	<b>M</b>
Field name	<b>Record type</b>			(Key field)	

Description: This field identifies the kind of data record in the message block. It contains the fixed value 'SA5'.

Processing outgoing

EDI subsystem:

BAAN: This field is filled with the fixed value 'SA5'.

Processing incoming

EDI subsystem: This field is filled with the fixed value 'SA5'.

BAAN: None

Position	<b>2</b>	Field format	<b>an..14</b>	Field status	<b>M</b>
Field name	<b>Message reference</b>			(Key field)	

Description: This field identifies all connected data records of one shipping schedule. The numbering, which has to be unique by shipping schedule, helps to control the chronological order of the schedules and the complete transmission.

Processing outgoing

EDI subsystem:

BAAN: Refer to record type SA2.

Processing incoming

EDI subsystem: Refer to record type SA2.

BAAN: Refer to record type SA2.

Position	<b>3 out</b>	Field format	<b>an..6</b>	Field status	<b>M</b>
Field name	<b>Supplier number</b>			(Key field)	

Description: This field contains the identification, which the customer applied to the supplier.

Processing outgoing

EDI subsystem:



BAAN: Refer to record type SA2.

Position	<b>3 in</b>	Field format	<b>an..17</b>	Field status	<b>M</b>
Field name	<b>Network address customer</b>				(Key field)

Description: This field contains the network address of the customer.

Processing incoming

EDI subsystem: Refer to record type SA2.

BAAN: Refer to record type SA2.

Position	<b>4</b>	Field format	<b>an..20</b>	Field status	<b>M</b>
Field name	<b>Code delivery address</b>				(Key field)

Description: This field contains the code for the delivery address of the customer.

Processing outgoing

EDI subsystem:

BAAN: Refer to record type SA2.

Processing incoming

EDI subsystem: Refer to record type SA2.

BAAN: Refer to record type SA2.

Position	<b>5</b>	Field format	<b>an..35</b>	Field status	<b>M</b>
Field name	<b>Customer's item number</b>				

Description: This field contains the identification, which the customer applied to the required item.

Processing outgoing

EDI subsystem:

BAAN: Refer to record type SA2.

Processing incoming

EDI subsystem: Refer to record type SA2.

BAAN: Refer to record type SA2.

Position	<b>6</b>	Field format	<b>an..35</b>	Field status	<b>M</b>
Field name	<b>Customer's item number for packaging</b>				

Description: This field contains the identification, which the customer applied to the packaging for the required item.

Processing outgoing

EDI subsystem:

BAAN: Mapping of BAAN table field  
tdpsc001.utyp/mtyp/btyp/atyp to position.

Processing incoming

EDI subsystem: Transmission of value from transmission file.

BAAN: Mapping to BAAN table field tdssc231.cpak.

Position	<b>7</b>	Field format	<b>an..35</b>	Field status	<b>C</b>
Field name	<b>Supplier's item number for packaging</b>				

Description: This field contains the identification number, which the supplier applied to the packaging for the required item. This field contains the same values as the previous position, because in BAAN there is only one article number by packaging available.

Processing outgoing

EDI subsystem:

BAAN: Mapping of BAAN table field  
tdpsc001.utyp/mtyp/btyp/atyp to position.

Processing incoming

EDI subsystem: Transmission of value from transmission file.

BAAN: Mapping to BAAN table field tdssc231.pack.

Position	<b>8</b>	Field format	<b>n..9</b>	Field status	<b>M</b>
Field name	<b>Quantity of items in package</b>				

Description: This field contains information about the capacity of the packaging.

The factor indicates how many units of the next smaller packaging are included in this packaging (format: nnnnnn.nn).

Processing outgoing

EDI subsystem:

BAAN: Mapping of BAAN table field  
tdpsc001.uqty/mqty/bqty/aqty to position.

Processing incoming

EDI subsystem: Transmission of value from transmission file.

BAAN: Mapping to BAAN table field tdssc231.cqty.

Position	<b>9</b>	Field format	<b>an1</b>	Field status	<b>M</b>
Field name	<b>Flag 'Full packaging only'</b>				

Description: This field indicates if the packaging has to be filled completely.

'1' = Yes (packaging has to be full)

'2' = No

Processing outgoing

EDI subsystem:

BAAN: Mapping of BAAN table field tdpsc001.iful/mful/bful/aful  
to position.

Processing incoming

EDI subsystem:

BAAN: This field is ignored.

Position	<b>10</b>	Field format	<b>an2</b>	Field status	<b>M</b>
Field name	<b>Qualifier item number</b>				

Description: This field contains the qualifier item number which is used to determine the item number from the *Customer's item number* in position 6. This position must be filled with the constant value 'SA' ('SA' = supplier's item number).

Processing outgoing

EDI subsystem:

BAAN: This field is filled with the fixed value 'SA'.

Processing incoming

EDI subsystem: This field is filled with the fixed value 'SA'.

BAAN: The qualifier must be present in BAAN table tcedi232 (Item number IDs). It is taken into account when the BAAN internal item number is determined from the customer's item number in position 5.

Position	<b>11</b>	Field format	<b>n1</b>	Field status	<b>M</b>
Field name	<b>Packaging Level</b>				

Description: This field indicates if the package is an inner or an outer package.

'1' = Inner Package

'2' = Intermediate Package

'3' = Outer Package/ Handling Unit (HU)

Processing outgoing

EDI subsystem:

BAAN: Mapping of "1", "2" or "3" .

Processing incoming

EDI subsystem: Transmission of the value from the transmission file.

BAAN: Mapping to BAAN table field tdscc231.plvl.

Position	<b>12</b>	Field format	<b>n1</b>	Field status	<b>C</b>
Field name	<b>Packaging Type</b>				

Description: This field indicates if the packaging is of type main or auxiliary  
 'M' = Main  
 'A' = Auxiliary

Processing outgoing

EDI subsystem:

BAAN: Mapping of "M" or "A".

Processing incoming

EDI subsystem: Transmission of the value from the transmission file.

BAAN: Mapping to BAAN table field tdssc231.ptyp.  
 An empty field will be converted to 'M'.

Position	<b>13</b>	Field format	<b>n..4</b>	Field status	<b>C</b>
Field name	<b>No of Packages</b>				

Description: Number of inner packages per outer package

Processing outgoing

EDI subsystem:

BAAN: left empty

Processing incoming

EDI subsystem: Transmission of the value from the transmission file.

BAAN: Mapping to BAAN table field tdssc231.puqt

Position	<b>14</b>	Field format	<b>an..3</b>	Field status	<b>C</b>
Field name	<b>Sales Unit</b>				

Description: Internal Sales Unit

Processing outgoing

EDI subsystem:

BAAN: Mapping of BAAN table field tdpssc001.cuqp to position.

Processing incoming

EDI subsystem: Transmission of the value from the transmission file.

BAAN: Mapping to BAAN table field tdssc231.cuqs by use of Conversion Table tcedi304.

Position	<b>15</b>	Field format	<b>an..35</b>	Field status	<b>C</b>
Field name	<b>Package Description</b>				

Description: Customer's Package description

Processing outgoing

EDI subsystem:

BAAN: left empty

Processing incoming

EDI subsystem: Transmission of the value from the transmission file.

BAAN: Mapping to BAAN table field tdssc231.dsca

Position	<b>16</b>	Field format	<b>an..3</b>	Field status	<b>C</b>
Field name	<b>Code List Agency</b>				

Description: Code list responsible agency

Processing outgoing

EDI subsystem:

BAAN: left empty

Processing incoming

EDI subsystem: Transmission of the value from the transmission file.

BAAN: Mapping to BAAN table field tdssc231.clra

Position	<b>17</b>	Field format	<b>an7</b>	Field status	<b>M</b>
Field name	<b>End of record marker</b>				

Description: The field indicates the end of the record. It contains the fixed value 'SA5\_END'.

Processing outgoing

EDI subsystem:

BAAN: The field is filled with the fixed value 'SA5\_END'.

Processing incoming

EDI subsystem: The field is filled with the fixed value 'SA5\_END'.

BAAN: None

Message Type Shipping Schedule  
2-62

(Definition of BEMIS 2.1 Inhouse Format)



### 3 Glossary of terms and abbreviations

ABRUF	Schedule
Appl	Application
ANSI	American National Standards Organization
BEM	Baan Electronic Message – abbreviated form of BEMIS used with the definition of the EDI organization
BEMIS	Baan Electronic Message Interchange System
Business partner (BP)	Customer or supplier
C	Conditional, that is, optional message
defaults.edi	Export file detailing master EDI data
DELINS	Odette Delivery Instruction (Schedule)
Directory	Folder
EDI	Electronic Data Interchange; electronic exchange of documents in standard formats
EDIFACT	Electronic Data Exchange For Administration, Commerce and Transport. An ISO standard.
ELP	External Logistic Provider
evaluation expression	Condition in the conversion setup for outgoing messages
ISO	International Standards Organization
ISO 4217	Code table
M	Mandatory (compulsory) message
MAIS	General Motor's interpretation of the subset of EDIFACT DELJIT Message
Messg	Message
network address	Folder (directory) path on network
ODDC	Odette Code Table
ODETTE	European standard for electronic data exchange
SCH	Supply Chain
Semaphore	Method to show a status by use of files with zero length
Translation	Conversion of one data format to another, for example Baan in-house data format to ODETTE
VAT	Value Added Tax (tax on turnover; sales tax)
VDA	Standard used for electronic data exchange in Germany
X12	Standard used for electronic data exchange in the United States

**Message Type Shipping Schedule (Definition of BEMIS 2.1 Inhouse Format)**  
3-2

## 4 Appendix

### Remarks about the conversion of plant/final delivery point in delivery address

When transmitting the messages:

- VDA 4905 (Shipping schedule incoming)
- VDA 4915 (Shipping schedule incoming)
- VDA 4916 (Production sequence requirement incoming)

Plant and final delivery point are expected to be transmitted as unique identification of the delivery point. BAAN uses a unique delivery address without making any distinctions about final delivery points. Therefore, it is necessary for the above mentioned incoming messages to carry out a conversion of the combination plant/final delivery point into a certain delivery address in BAAN.

The following code- and conversion tables have to be used for the conversion:

#### 1 Address types (tcedi214)

Maintain address types		Company: 600
<u>Organization</u>	: BEM BAAN Electr. Message Int. Sys.	
<u>Code in Message</u>	Description	
ZZ	Delivery address	Choice: ..

These parameters need to be entered once by organisation (BEM).

2 Address Code IDs (tcedi218)

Maintain Address Code IDs		Firma: 600
<u>Organization</u>	:	BEM BAAN Electr. Message Int. Sys.
<u>Code in Message</u>	Description	
DP	Delivery address	Choice: ..

These parameters need to be entered once by organisation (BEM).

3 Delivery address codes by customer incoming (tcedi310)

Maintain Conv. Of Del. Addr. Codes by Customer (in)		Company: 600
<u>Customer</u>	:	000001 Volkswagen AG
<u>Organization</u>	:	BEM Verband der deutschen autoind.
<u>Address Code ID</u>	:	DP Delivery Address
<u>Code in Message</u>		Code in Application
01601QC		001 Werk Wolfsburg Tor1
01602QC		002 Werk Wolfsburg Tor2
		Choice: ..

The conversion of the plant/final delivery point into the delivery address (code in application) is entered into this table referring to one customer. The parameters have to be entered for every plant/final delivery point combination of one customer.

## Sample file

```

"SA1";"F8009711240003";"005122";"F800";"FAB-
IO";"BEMIS";"";"Auftr.ref.":971124;1313;"Nach.ref. alt";"SA1_END"

"SA2";"F8009711240003";"005122";"WEKAblad";"MB1";"DP";"ZZ";"SA";"M
B1";"005122_MB1";"K005122";"WEK";"Ablad";"001";"Band1";100014;97112
4;"S";
";"2";"100100";0;971124;"LSNR001";971124;1000;"I";";";"971124;0;"I";";";
971124;0;"I";"ZwiLief."; "Erg. SachNr.";0;971124;"SA2_END"

"SA3";"F8009711240003";"005122";"WEKAblad";"MB1";"Liefertext
11111111111111111111111111111111111111";"Liefertext
2222222222222222222222222222222222222222";"Liefertext
33333333333333333333333333333333333333";"SA3_END"

"SA4";"F8009711240003";"005122";"WEKAblad";"MB1";971124;1000;1000;"
";"1A";"SA4_END"

"SA4";"F8009711240003";"005122";"WEKAblad";"MB1";971125;1000;1000;"
";"SA4_END"

"SA4";"F8009711240003";"005122";"WEKAblad";"MB1";971126;1000;1000;"
";"2A";"SA4_END"

"SA4";"F8009711240003";"005122";"WEKAblad";"MB1";971127;1000;1000;"
";"3A";"SA4_END"

"SA4";"F8009711240003";"005122";"WEKAblad";"MB1";971128;1000;1000;"
";"4A";"SA4_END"

"SA4";"F8009711240003";"005122";"WEKAblad";"MB1";971129;1000;1000;"
";"5A";"SA4_END"

"SA4";"F8009711240003";"005122";"WEKAblad";"MB1";971130;1000;1000;"
";"6A";"SA4_END"

"SA4";"F8009711240003";"005122";"WEKAblad";"MB1";971201;1000;1000;"
";"7A";"SA4_END"

"SA4";"F8009711240003";"005122";"WEKAblad";"MB1";971201;1100;1000;"
";"8A";"SA4_END"

"SA4";"F8009711240003";"005122";"WEKAblad";"MB1";971201;1200;1000;"
";"9A";"SA4_END"

"SA4";"F8009711240003";"005122";"WEKAblad";"MB1";971201;1300;1000;"
";"10A";"SA4_END"

```

"SA5";"F8009711240003";"005122";"WEKAblad";"MB1";"0000100100";"0000100100";1;1;"SA5\_END"

"SA1";"F8009712120043";"005122";"F800";"FAB-IO";"BEMIS";"";"Auftr.ref.";971212;1158;"Nach.ref. alt";"SA1\_END"

"SA2";"F8009712120043";"005122";"WEKAblad";"MB1";"DP";"ZZ";"SA";"MB1";"005122\_MB1";"";"WEK";"Ablad";"LADERAMPE";"Linie 1";100200;971212;"S";"KZ Krit. Best";;"2";"100100";;0;971212;"";971212;0;"I";"";971212;0;"I";"ZwiLief."; "Erg. SachNr.";0;971212;"SA2\_END"

"SA3";"F8009712120043";"005122";"WEKAblad";"MB1";"Liefertext1";"Liefertext 22222222222222222222222222222222";"SA3\_END"

"SA4";"F8009712120043";"005122";"WEKAblad";"MB1";971212;0;0;"";"1B";;"SA4\_END"

"SA4";"F8009712120043";"005122";"WEKAblad";"MB1";971212;1000;100;"";"2B";;"SA4\_END"

"SA4";"F8009712120043";"005122";"WEKAblad";"MB1";971213;1000;100;"";"3B";;"SA4\_END"

"SA4";"F8009712120043";"005122";"WEKAblad";"MB1";971214;1000;100;"";"4B";;"SA4\_END"

"SA4";"F8009712120043";"005122";"WEKAblad";"MB1";971215;1000;100;"";"5B";;"SA4\_END"

"SA4";"F8009712120043";"005122";"WEKAblad";"MB1";971216;0;100;"";"6B";;"SA4\_END"

"SA4";"F8009712120043";"005122";"WEKAblad";"MB1";971217;1000;100;"";"7B";;"SA4\_END"

"SA4";"F8009712120043";"005122";"WEKAblad";"MB1";971218;1000;100;"";"SA4\_END"

"SA4";"F8009712120043";"005122";"WEKAblad";"MB1";971222;1000;100;"";"8B";;"SA4\_END"

"SA4";"F8009712120043";"005122";"WEKAblad";"MB1";980101;1000;100;"";"9B";;"SA4\_END"

"SA5";"F8009712120043";"005122";"WEKAblad";"MB1";"RACK";"RACK";1;1;"SA5\_END"

"SA5";"F8009712120043";"005122";"WEKAblad";"MB1";"RACK1";"RACK1";1;2;"SA5\_END"