

# Definition of BEMIS MRL001 Import and Export File for Business Document Type Material Release



---

Copyright © 2008 Infor

All rights reserved. The word and design marks set forth herein are trademarks and/or registered trademarks of Infor and/or related affiliates and subsidiaries. All rights reserved. All other trademarks listed herein are the property of their respective owners.

### Important Notices

The material contained in this publication (including any supplementary information) constitutes and contains confidential and proprietary information of Infor.

By gaining access to the attached, you acknowledge and agree that the material (including any modification, translation or adaptation of the material) and all copyright, trade secrets and all other right, title and interest therein, are the sole property of Infor and that you shall not gain right, title or interest in the material (including any modification, translation or adaptation of the material) by virtue of your review thereof other than the non-exclusive right to use the material solely in connection with and the furtherance of your license and use of software made available to your company from Infor pursuant to a separate agreement ("Purpose").

In addition, by accessing the enclosed material, you acknowledge and agree that you are required to maintain such material in strict confidence and that your use of such material is limited to the Purpose described above.

Although Infor has taken due care to ensure that the material included in this publication is accurate and complete, Infor cannot warrant that the information contained in this publication is complete, does not contain typographical or other errors, or will meet your specific requirements. As such, Infor does not assume and hereby disclaims all liability, consequential or otherwise, for any loss or damage to any person or entity which is caused by or relates to errors or omissions in this publication (including any supplementary information), whether such errors or omissions result from negligence, accident or any other cause.

### Trademark Acknowledgements

All other company, product, trade or service names referenced may be registered trademarks or trademarks of their respective owners.

### Publication Information

**Document code:** U9443A US

**Release:** ERP LN 6.1 Electronic Commerce

**Publication date:** July 08

---



---

# Table of Contents

<b>Chapter 1</b>	<b>General Principles .....</b>	<b>1-1</b>
	Available types of data records .....	1-1
	Branching diagrams .....	1-2
	Key fields outgoing.....	1-4
	Key fields incoming .....	1-5
	Business partner relations.....	1-5
	Network directories .....	1-6
	ERP LN BEMIS messages – conventions.....	1-8
	What is new in comparison to BEMIS for BAAN V? .....	1-10
<b>Chapter 2</b>	<b>Data Record Description by Type of Data Record .....</b>	<b>2-1</b>
	SA1 Message Overhead .....	2-1
	SA2 Release Header .....	2-10
	SA3 Schedule Header.....	2-22
	SA4 Schedule Header Text.....	2-41
	SA5 Schedule Authorizations.....	2-47
	SA6 Schedule Lines.....	2-54
<b>Chapter 3</b>	<b>Definitions, Acronyms, and Abbreviations.....</b>	<b>3-1</b>
<b>Appendix A</b>	<b>Sample file.....</b>	<b>A-1</b>

---



## About this Guide

### Objective

This document describes the content and the corresponding structure of the EDI message “Material Release”, which is supported by Baan Electronic Message, the ERP LN in-house format.

The message’s content refers to the following “Long – Time Delivery Instruction” origin message types and gives their attribution to the transferred ASCII file of the BEMIS format:

- EDIFACT DELFOR
- ANSI X12 830
- VDA 4905

The message structure is defined by referring to incoming directions and outgoing directions.

The document contains the following chapters:

Chapter 1, “General Principles”, provides a general introduction to the EDI in-house format for the Business Document type Material Release.

Chapter 2, “Data Record Description by Kind of Data Record”, describes in detail the data records used for the EDI in-house format of EDI message Material Release.

Chapter 3, “Definitions, Acronyms, and Abbreviations”, provides a glossary of terms used in Infor ERP LN and in this document, and also a list of abbreviations.

Appendix A, “Sample File”, provides a sample file for the outgoing message MRL001.

---

## Intended audience

This document is intended for the following categories of users:

- Users who want to understand what the processed information of the EDI messages in ERP LN are.
- Users who develop the translation from external EDI format to the in-house format.

## References

The following documents might be of importance:

No.	Document number	Title
1	U8912A US	<i>User's Guide for BEMIS</i>
2	U8998A US	<i>User's Guide for EDI Business Documents</i>
3	U9446A US	<i>Definition of BEMIS SHP001 Import and Export file...</i>

## Send us your comments

We continually review and improve our documentation. Any remarks/requests for information concerning this document or topic are appreciated. Please e-mail your comments to [documentation@infor.com](mailto:documentation@infor.com).

In your e-mail, refer to the document code and title. More specific information will enable us to process feedback efficiently.

---



---

# Chapter 1

## General Principles



### Available types of data records

This section describes the EDI In-house format for the Business Document type Material Release (incoming/outgoing). When you transmit information about material releases, the use of the following types of data records is conditional (C) or respectively mandatory (M).

<b>ID</b>	<b>Status</b>	<b>Name</b>
<b>SA1</b>	<b>M</b>	<b>Global Overhead</b>
<b>SA2</b>	<b>M</b>	<b>Release Header</b>
<b>SA3</b>	<b>M</b>	<b>Schedule Header</b>
<b>SA4</b>	<b>C</b>	<b>Schedule Header Text</b>
<b>SA5</b>	<b>M</b>	<b>Authorizations</b>
<b>SA6</b>	<b>M</b>	<b>Schedule Lines</b>

---

## Branching diagrams

The following data record structure is used for the BEMIS message type Material Release:

Level

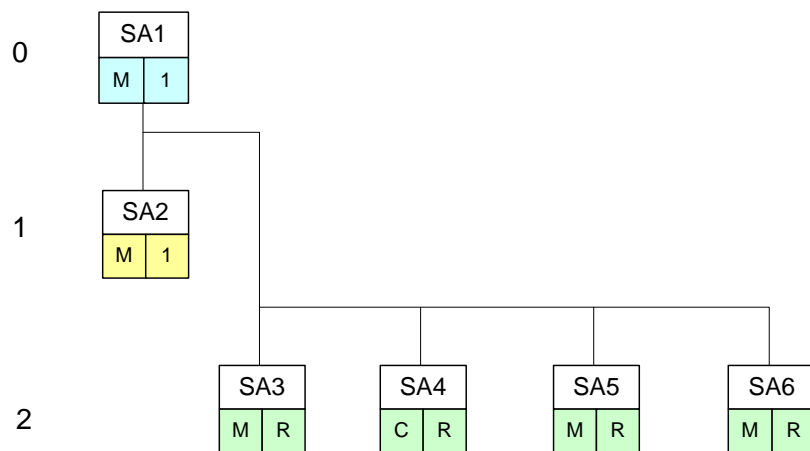

Legend:

Status:

M: mandatory in message

C: conditional in message

Frequency:

1: once by message

R: repeatable by message

For example, for two required releases with each two schedules the BEMIS file has the following structure:

SA1 ... Global Overhead

SA2 ... Release Header 1

SA3 ... Schedule Header 1

SA5. ... Authorizations 1

SA6 ... Schedule Line 11

SA6 ... Schedule Line 12

SA3 ... Schedule Header 2

SA4 ... Schedule Text 2

SA5 ... Authorizations 2

SA6 ... Schedule Line 21

SA1 ... Global Overhead

SA2 ... Release Header 2

SA3 ... Schedule Header 1

SA4 ... Schedule Text 1

SA5... Authorizations

SA6 ... Schedule Line 11

SA3 ... Schedule Header 2

SA4.... Schedule Text 2

SA5 ... Authorizations 2

SA6 ... Schedule Line 21

SA6 ... Schedule Line 22

SA6 ... Schedule Line 23

---

## Key fields outgoing

The outgoing message refers to the Buy-from-BP and the Purchase Schedule Release. The following structure of the key fields is used to determine the corresponding data records of a Material Release message:

Sorted by Key							
Kind	Data Rec.	key 1	key 2	key 3	key 4	key 5	key 6
field 1	Backpt						
SA1		Message ref.	BP net ID				
SA2	1	Message ref.	BP net ID				
SA3	2	Message ref.	BP net ID	Release	Release revision		
SA4	3	Message ref.	BP net ID	Release	Release revision	Release Position	Schedule
SA5	3	Message ref.	BP net ID	Release	Release revision	Release Position	Schedule
SA6	3	Message ref.	BP net ID	Release	Release revision	Release Position	Schedule

## Key fields incoming

The incoming message refers to the Sold-to-BP and the Sales Schedule Releases. The following structure of the key fields is used to determine the corresponding data records of a Material Release message:

Sorted by Key							
Kind	Data Rec.	key 1	key 2	key 3	key 4	key 5	key 6
field 1	Backpt						
SA1		Message ref.	BP net ID				
SA2	1	Message ref.	BP net ID				
SA3	2	Message ref.	BP net ID	Release	Release Revision		
SA4	3	Message ref.	BP net ID	Release	Release Revision	Release Position	Schedule
SA5	3	Message ref.	BP net ID	Release	Release Revision	Release Position	Schedule
SA6	3	Message ref.	BP net ID	Release	Release Revision	Release Position	Schedule

## Business partner relations

The following table shows the business partner relations:

Outgoing Schedule Releases		Incoming Schedule Releases	
ID of the sender	ecedi020.neta	Sold-to BP Code	tdsls312.ofbp
Ship-From BP-Code	tdpur320.sfbp	Warehouse Code	tdsls307.cwar
Warehouse Code	tdpur320.cwar	Ship-to BP Code	tdsls312.stbp
Ship-to Address Code	tdpur320.stad	Ship-to Address Code	tdsls312.stad

## Network directories

In the Direct Network Communication (ecedi7205m000) session, the user can receive and generate EDI messages.

As written in the User's Guide EDI Business Document [2], the communication is done between the EDI Sub-System and ERP LN to transfer the message's ASCII files across the specific network. This communication is based on the network directories that are established in ERP LN.

The network basis directories for each network will be defined in the ecedi0120m000 session.

The ERP LN user can decide the structure of the used network directories, such as the following:

- For every message type, one network directory can be used for outgoing messages and one can be used for incoming messages. This means that one message file contains data for several business partners.
- For a group of message types, such as schedules, one network directory can be used for outgoing messages and one can be used for incoming messages.
- Every business partner can use their own network directory, and the files would be able to contain data for several messages types.

Infor recommends using the first possibility or the second possibility if the MRL001 could be specified by Shipping Schedules [3].

For the network BEMIS, for example, the basis directories can be indicated in the following way:

```
/${BSE}/edi/bemis/schedule/
```

---

ERP LN will additionally create the following subdirectories:

- `/${BSE}/edi/bemis/schedule/appl_from/`
- `/${BSE}/edi/bemis/schedule/appl_to/`
- `/${BSE}/edi/bemis/schedule/command/`
- `/${BSE}/edi/bemis/schedule/store_rcv/`
- `/${BSE}/edi/bemis/schedule/store_sent/`
- `/${BSE}/edi/bemis/schedule/trace/`

The above mentioned directories refer to one message type, “material release”. The directories have the following functions:

- **.../appl\_from/:** In this directory, ERP LN records the outgoing messages that are the defined BEMIS in-house format files. The EDI Subsystem can collect them from here.
- **.../appl\_to/:** The EDI Subsystem writes the incoming message into this directory in the ERP LN in-house format.
- **.../command/:** A directory of the semaphores.
- **.../store\_rcv/:** ERP LN stores processed incoming messages in this directory, if the corresponding EDI parameter is set in this way. During this process, an additional subdirectory by incoming message file is created; the subdirectory is named with a date and time stamp that indicates when the message was moved.
- **.../store\_sent/:** ERP LN stores processed outgoing messages in this directory, if the corresponding EDI parameter is set in this way. During this process, an additional subdirectory by incoming message file is created; the subdirectory is named with a date and time stamp that indicates when the message was moved.
- **.../trace/:** ERP LN creates a log of the incoming messages and outgoing messages in the processing order in this directory, if the corresponding EDI parameter is set in this way.

The file name of the BEMIS in-house format files of the material release, which is being described in this documentation, is defined in the following way:

Direction	File Name	Network Directory
outgoing	MRL001	<code>/\${BSE}/edi/bemis/schedule/appl_from</code>
incoming	MRL001	<code>/\${BSE}/edi/bemis/schedule/appl_to</code>

## ERP LN BEMIS messages – conventions

Written in the User’s Guide for BEMIS [1], we use the following rules to structure the EDI message:

- Each data segment is defined by a unique code in an EDI message. The format of the data segment code is SA99. Each segment (message record) starts with the unique code “Sax”; the message record ends with “SAx\_END”.
- The length of the several data segments can vary.
- Even if some fields do not contain a value, each data segment (message record) must consist of all fields.
- The fields in the file must be separated by a defined sign, such as a semicolon (;)
- A filled string field must be put inside quotation marks (“...”).
- If a position in a BEMIS Message File is not taken by a value, which means that the position is empty, then the position is pointed out using two semicolons. Also, the ERP LN EDI Module distinguishes between numerical data and alphanumerical data format, as shown in the following examples:

Empty numerical Position:       “SAx”; ... ; ; ... ;”SAx\_END”

Empty alphanumerical Position: Infor differs between the following, in case the field exists in the LN database:

“SAx”; ... ; ; ... ;”SAx\_END”   and   “SAx”; ... ; “”; ... ;”SAx\_END”

In the following sections are the format descriptions of the individual types of data segments (message records) of the interface file. The table contains the following data:

### MATERIAL RELEASE IN-HOUSE FORMAT

Pos	Field description	Key	ST	FM
-----	-------------------	-----	----	----

The first block of the table describes the format of a type of data record:

Pos                               Position of the field in the data record

Field description   Description of the field

---



Key	Key field outgoing (O) / incoming (I)
ST	Field status mandatory (M) / conditional (C)
FM	Field format, for example. an..14 = alphanumerical field with a maximum of 14 characters an14 = alphanumerical field with exactly 14 characters n..10 = numerical field with a maximum of 10 characters n1 = numerical field with exactly 1 character

The second block of the table describes the corresponding table field in ERP LN and describes possible special actions, which will be carried out when the messages are being processed.

**from Application Table Field (out) / Mapping to Table Field (in)**

Table Field	Action

Following the table overview, every field is described in a more detailed way, including information about the processing in the EDI Sub-System and in ERP LN.

Consider one exception: if a position of the data record is not currently used, then Infor omits the detailed description of this empty position.

## What is new in comparison to BEMIS for BAAN V?

The EDI Delivery Schedule Message referring to the EDIFACT DELFOR could not be processed in Baan V standard software.

The ERP LN includes the EDI Schedule processing similarly to the Purchase and Sales Schedule application of the Baan IV SCH / SCC / AGS versions.

Additionally the ERP LN In-house format considers the processing of several schedule's releases. The release gives a possibility to collect several schedules and to track the transferred schedules of a Business Partner. The covering is done by the mandatory data record SA2 in MRL. A schedule release is only used for the EDI processing.

# Chapter 2

## Data Record Description by Type of Data Record

### SA1 Message Overhead

Status: Mandatory

Frequency: Once by Release

Description: This data record contains information about the transmitter, the message type and the time of the transmission. The message reference identifies all related data records of this message.

MRL In-house Format					Mapping from Application Table Fields (out)		Mapping to Application Table Fields (in)	
Pos	Field Description	Key	ST	FM	Table field	Action	Table field	Action
1	Kind of data record	O/I	M	an3	SA1		SA1	
2	Message Reference	O/I	M	an..35	ecedi701.bano	Generation (see below)	ecedi702.bano	Generation by EDI Sub-System
3	Net ID of Sender	O/I	M	an..17	ecedi020.neta	Conversion (see below)	ecedi702.bpid	Conversion (see below)
4	Net ID of Receiver		M	an..17	ecedi028.neta	Conversion		

MRL In-house Format					Mapping from Application Table Fields (out)		Mapping to Application Table Fields (in)	
Pos	Field Description	Key	ST	FM	Table field	Action	Table field	Action
					(see below)			
5	Message		M	an..6	ecedi001.code	Conversion (see below)	ecedi028.mess	Conversion (see below)
6	Organization		M	an..6	ecedi003.code	Conversion (see below)	ecedi702.orga	Conversion (see below)
7	Order type		M	an..35	empty (...;...)		ecedi702.koor	
8	Transmission reference		M	an..20	ecedi700.orno		ecedi702.msno	
9	Date / Time of transmission		M	n..14	current date / time		ecedi702.sent	
10	Transmission Reference old		C	an..20	empty (...;...)		ecedi702.prno	
11	Identification of the technical message creator		C	an..35	ERP LN.6.1			
12	Identifier of Test		C	an1	ecedi003.test	Empty means original message.	ecedi702.test	
13	Data record end sign		M	an7	SA1_END		SA1_END	

Detailed description: Material Release  
 Kind of data record: SA1 Message Overhead

Position	1	Field Format	an3	Field Status	M
Field Name	<u>Kind of Data Record</u>		Key field Out / IN		
Description	This field identifies the kind of data record in the message block. It contains the constant value 'SA1'.				
Processing outgoing EDI Sub-System					
ERP LN	This field will be filled with the constant value 'SA1'.				
Processing Incoming EDI Sub-System	This field will be filled with the constant value 'SA1'.				
ERP LN	None				

Position	2	Field Format	an..14	Field Status	M
Field Name	<u>Message Reference</u>		Key field Out / IN		
Description	<p>This field identifies all connected data records of one Material Release. The numbering, which has to be clear by MRL, helps to control the chronological order of the MRL and the complete transmission. The field consists of a fix item with four characters, the current date (format: YYYYMMDD) and a serial number with four characters.</p> <p>The special format will be defined in the network parameters in the ERP LN table ecedi020. When generating the message reference with the EDI Sub-System, the created message reference needs to be specific, which means unique. While storing the message reference ERP LN controls whether it is specific.</p>				
Processing outgoing EDI Sub-System					
ERP LN	ERP LN generates this number to identify a Material Release, stores it in the ERP LN table field ecedi701.bano and writes it into all data records of a MRL.				
Processing Incoming EDI Sub-System	The EDI Sub-System generates this number to identify a Material release and writes it into all data records of a MRL.				
ERP LN	Mapping to ERP LN table field ecedi702.bano.				

<b>Position</b>	<b>3</b>	<b>Field Format</b>	<b>an..17</b>	<b>Field Status</b>	<b>M</b>
<b>Field Name</b>	<b><u>Net ID of sender</u></b>		<b>Key field Out / In</b>		

Description This field contains the identification of the sender (for example the ILN Number)

Processing outgoing  
EDI Sub-System Transmission of the value from the message file.

ERP LN The identification is stored in the ERP LN table ecedi020 'Our Identification' under the corresponding network in the ERP LN table field ecedi020.neta. The content of this field is mapped to the position of the transmission file. Here you can store the general ILN-Number for your customer.

Processing Incoming  
EDI Sub-System

ERP LN The identification of the sender determines the corresponding business partner (customer) and the network in the table ecedi028 'Relations by network'. This identification is mapped to the ERP LN table field ecedi702.bpid.

<b>Position</b>	<b>4</b>	<b>Field Format</b>	<b>an..17</b>	<b>Field Status</b>	<b>M</b>
<b>Field Name</b>	<b><u>Net ID of Receiver</u></b>				

Description This field contains the identification of receiver.

Processing outgoing  
EDI Sub-System

ERP LN The identification of the receiver (for example the ILN of the receiver) in the used network is entered in the table ecedi028. The ELP LN table field ecedi028.neta is mapped to this position.

Processing Incoming  
EDI Sub-System Transmission of the value from the message file.

ERP LN On the incoming side this field will be ignored.

---

Position	5	Field Format	an..6	Field Status	M
<b>Field Name</b>	<b><u>Message</u></b>				
Description	This field contains the code for the identification of the concerned message. The code for the message type 'Material Release' is MRL001.				
Processing outgoing EDI Sub-System	.				
ERP LN	The internal message code ecedi001.code 'MRL001' of the ERP LN table ecedi001 'Supported EDI messages' is mapped to this position.				
Processing Incoming EDI Sub-System	This field will be filled with the constant value 'MRL001'.				
ERP LN	The message code in the table ecedi001 'Supported EDI Messages' determines which internal message in ERP LN is connected to this MRL. In the ERP LN table ecedi005 'EDI Messages' is determined for every message which session (DLL) is used in ERP LN to process the message. The message code is mapped to the ERP LN table field ecedi702.mess.				

Position	6	Field Format	an..6	Field Status	M
<b>Field Name</b>	<b><u>Organization</u></b>				
Description	This field contains the organization (Standard), which is used for the EDI communication.				
Processing outgoing EDI Sub-System					
ERP LN	The internal organization code ecedi003.code 'BEMIS' from the ERP LN table ecedi003 'Organizations' is mapped to this position.				
Processing Incoming EDI Sub-System	This field will be filled with the constant value 'BEMIS'.				
ERP LN	Mapping to ERP LN table field ecedi702.org. The corresponding Organization must have been entered into the ERP LN table ecedi003.None				

<b>Position</b>	<b>7</b>	<b>Field Format</b>	<b>an..35</b>	<b>Field Status</b>	<b>M</b>
<b>Field Name</b>	<b><u>Order Type</u></b>				

Description This field contains a code for the concerned order type; the field is empty referring to MRL001.

Processing outgoing  
EDI Sub-System

ERP LN

Processing Incoming  
EDI Sub-System

ERP LN Mapping to ERP LN table field ecedi702.koor. In the ERP LN table ecedi200 there must be an entry for this order type in connection with the respective message and organization.

<b>Position</b>	<b>8</b>	<b>Field Format</b>	<b>an..20</b>	<b>Field Status</b>	<b>M</b>
<b>Field Name</b>	<b><u>Transmission Reference</u></b>				

Description This field contains the reference code which the EDI Sub-System applied to this transmission.

Processing outgoing  
EDI Sub-System

ERP LN The position will be filled with the schedule release number from ERP LN table field ecedi700.orno

Processing Incoming  
EDI Sub-System

ERP LN Mapping to ERP LN table field ecedi702.msno.

---



Position	9	Field Format	n..14	Field Status	M
<b>Field Name</b>	<b><u>Date / Time of Transmission</u></b>				

Description This field contains on the outgoing side the current date / time, on which the MRL message was created. On the incoming side, this field contains the arrival date / time of the message at the EDI Sub-System (format: YYYYMMDDHHMMSS).

Processing outgoing  
EDI Sub-System

ERP LN Mapping of the current date / time to the position.

Processing Incoming  
EDI Sub-System Entry of the arrival date / time of the message at the EDI Sub-System.

ERP LN Mapping to ERP LN table field ecedi702.send

Position	10	Field Format	an..20	Field Status	C
<b>Field Name</b>	<b><u>Transmission Reference Old</u></b>				

Description This field contains the reference number, which the EDI Sub-System applied to the previous transmission.

Processing outgoing  
EDI Sub-System

ERP LN Not used

Processing Incoming  
EDI Sub-System Transmission of the value from the transmission file.

ERP LN Mapping to ERP LN table field ecedi702.pno.

<b>Position</b>	<b>11</b>	<b>Field Format</b>	<b>an..35</b>	<b>Field Status</b>	<b>C</b>
<b>Field Name</b>	<b><u>Identification of the technical message creator</u></b>				

Description This fields contains an identification of the technical message creator

Processing outgoing  
EDI Sub-System

ERP LN The position could be filled with a constant value as 'ERP LN'; currently the field is empty.

Processing Incoming  
EDI Sub-System The EDI Sub System put its identifier to this position.

ERP LN None

<b>Position</b>	<b>12</b>	<b>Field Format</b>	<b>an1</b>	<b>Field Status</b>	<b>C</b>
<b>Field Name</b>	<b><u>Identifier of Test</u></b>				

Description This field contains the code that will identify incoming messages for this organization as test messages. A test message is checked, but not copied to the database.

Processing outgoing  
EDI Sub-System

ERP LN The position will be filled with the ERP LN table field ecedi003.test

Processing Incoming  
EDI Sub-System Transmission of the value from the transmission file.

ERP LN Mapping to ERP LN table field ecedi702.test.

---

---

Position	13	Field Format	an7	Field Status	M
<b>Field Name</b>	<b><u>Data Record end sign</u></b>				
Description	This field identifies the end of data record in the message block. It contains the constant value 'SA1_END'.				
Processing outgoing EDI Sub-System					
ERP LN	This field will be filled with the constant value 'SA1_END'.				
Processing Incoming EDI Sub-System	This field will be filled with the constant value 'SA1_END'.				
ERP LN	None				

---

## SA2 Release Header

Status: Mandatory

Frequency: Once by Release

Description: This data record contains all information of the Release Header except of text data, and it is related to SA1.

MRL In-house Format					Mapping from Application Table Fields (out)		Mapping to Application Table Fields (in)	
Pos	Field Description	Key	ST	FM	Table field	Action	Table field	Action
1	Kind of data record	O/I	M	an3	SA2		SA2	
2	Message Reference	O/I	M	an..35	ecedi701.bano	Generation (see below)	ecedi702.bano	Generation by EDI Sub-System
3	(Net) ID of Sender	O/I	M	an..17	ecedi020.neta	Conversion (see below)	tdsls312.ofbp	Conversion (see below)
4	Release No.		M	an..9	tdpur320.rlno		tdsls312.crln	
5	Release revision		M	n..4	tdpur320.rlr		tdsls312.crlr	
6	Release type		M	an6	tdpur320.rtyp		tdsls312.rtyp	
7	Transaction set purpose		M	an7	"Replace"			
8	Qualifier Buy-from BP		M	an6	"OFBP"			
9	Buy-from BP		M	an..9	tdpur320.bfbp			
10	Qualifier Ship-to BP		M	an6	"STBP"			
11	Ship-from BP		M	an..9	tdpur320.sfbp			
12	Ship-to-Address		M	an..6	tdpur320.stad	Conversion	tdsls312.stad	Conversion
13	Shipment/delivery based		M	n1	tdpur320.tqal	Conversion Schedule Type	tdsls312.sodb	Conversion

MRL In-house Format					Mapping from Application Table Fields (out)		Mapping to Application Table Fields (in)	
Pos	Field Description	Key	ST	FM	Table field	Action	Table field	Action
14	Schedule quantity qualifier		M	an1	"A"		tdsls312.qqal	Conversion
15	Forecast Horizon Start Date		C	n..22	tdpur320.fohs		tdsls312.fohs	
16	Forecast Horizon End Date		C	n..22	tdpur320.fohe		tdsls312.fohe	
17	Generation Date		M	n..22	tdpur320.egdt		tdsls312.egdt	
18	Qualifier Address Code		C	an..6	ZZ		ZZ	
19	Warehouse / Ship-to BP		M	an..6	tdpur320.cwar		tdsls312.stpb	Conversion
20	Data Record End Sign	O/I	M	an7	SA2_END		SA2_END	

Detailed description: Material Release  
 Kind of data record: SA2 Release Header

Position	1	Field Format	an3	Field Status	M
Field Name	<u>Kind of Data Record</u>		Key field Out / IN		
Description	This field identifies the kind of data record in the message block. It contains the constant value 'SA2'.				
Processing outgoing EDI Sub-System					
ERP LN	This field will be filled with the constant value 'SA2'.				
Processing Incoming EDI Sub-System					
ERP LN	None				

Position	2	Field Format	an..35	Field Status	M
Field Name	<u>Message Reference</u>		Key field Out / IN		
Description	This field identifies all connected data records of one Material Release. The numbering, which has to be clear by MRL, helps to control the chronological order of the Material Releases and the complete transmission.				
Processing outgoing EDI Sub-System					
ERP LN	Analogously to data record SA1				
Processing Incoming EDI Sub-System					
ERP LN	Analogously to data record SA1				

---

Position	3	Field Format	an..17	Field Status	M
Field Name	<u>(Net) ID of sender</u>		Key field Out / In		
Description	This field contains the identification of the sender (for example the ILN Number)				
Processing outgoing EDI Sub-System	Transmission of the value from the message file.				
ERP LN	The identification is stored in the ERP LN table ecedi020 'Our Identification' under the corresponding network in the ERP LN table field ecedi020.neta. The contents of this field are mapped to the position of the transmission file. Here you can store the general ILN-Number for your customer.				
Processing Incoming EDI Sub-System					
ERP LN	The identification of the sender determines the corresponding business partner (customer) and the network in the table ecedi028 'Relations by network'. This identification is mapped to the ERP LN table field tdsls312.ofbp. Pos. 18 is used as first qualifier, pos. 8 as second qualifier.				

Position	4	Field Format	an..9	Field Status	M
Field Name	<u>Release Number</u>		Key field Out / In		
Description	This field contains the origin Release Number of the related schedules.				
Processing outgoing EDI Sub-System	None				
ERP LN	The Release number is mapped from ERP LN table field tdpur320.rln0 to this position.				
Processing Incoming EDI Sub-System	Transmission of the value from the message file.				
ERP LN	Mapping to ERP LN table field tdsls312.crln; the customer release				

Position	5	Field Format	n..4	Field Status	M
<b>Field Name</b>	<b><u>Release Revision Number</u></b>		<b>Key field</b>		

Description	This field contains the Release Revision Number.
Processing outgoing EDI Sub-System	None
ERP LN	The Release number is mapped from ERP LN table field tdpur320.rlv to this position.
Processing Incoming EDI Sub-System	Transmission of the value from the message file.
ERP LN	Mapping to ERP LN table field tdsls312.crlr; customer's release revision.

Position	6	Field Format	an6	Field Status	M
<b>Field Name</b>	<b><u>Release Type</u></b>		<b>Key field</b>		

Description	This field contains the Release Type to identify the kind of schedules.
Processing outgoing EDI Sub-System	None
ERP LN	The Release type equals the type of EDI message. It is mapped from the ERP LN table field tdpur320.rtyp to this position. It contains the numeric value 1 (Material Release).
Processing Incoming EDI Sub-System	Transmission of the value from the message file.
ERP LN	Mapping to ERP LN table field tdsls312.rtyp



Position	7	Field Format	an7	Field Status	M
<b>Field Name</b>	<b><u>Transaction set Purpose</u></b>		<b>Key field</b>		

Description This field describes the type of the release that is transmitted. It can be of type 'Replace', 'Update', 'Cancel' etc.

Processing outgoing  
EDI Sub-System

None

ERP LN

This field will be filled with the constant value equivalent to 'Replace'.

Processing Incoming  
EDI Sub-System

ERP LN

Position	8	Field Format	an6	Field Status	M
<b>Field Name</b>	<b><u>Qualifier Buy-from-BP</u></b>		<b>Key field</b>		

Description This position contains the qualifier to identify the Business partner.

Processing outgoing  
EDI Sub-System

None

ERP LN

This field will be filled with the constant value "OFBP"

Processing Incoming  
EDI Sub-System

Transmission of the value from the message file.

ERP LN

Field can be used as qualifier 2 on field tdsIs312.ofbp (field 3).

Position	9	Field Format	an..9	Field Status	M
<b>Field Name</b>	<b><u>Buy-from-BP / Sold-to-BP</u></b>		<b>Key field</b>		
Description	This position contains the code for the Business Partner where the customer buys its goods.				
Processing outgoing EDI Sub-System	None				
ERP LN	The Code for the Buy From Business Partner from ERP LN table field tdpur400.otbp is converted using the conversion table ecedi463 and the default Qualifier "ZZ", and it is mapped to this position.				
Processing Incoming EDI Sub-System	Transmission of the value from the message file.				
ERP LN	The Code for the Sold-To-Business Partner has to convert using the conversion table ecedi363 and Address Code ID given in ecedi224 = "ZZ", and it has to map to the EREP LN table field tdsis400.ofbp.				

Position	10	Field Format	an6	Field Status	M
<b>Field Name</b>	<b><u>Qualifier Ship-to-BP</u></b>		<b>Key field</b>		
Description	This position contains the qualifier to identify the Business partner.				
Processing outgoing EDI Sub-System	None				
ERP LN	This field will be filled with the constant value "STBP"				
Processing Incoming EDI Sub-System	Transmission of the value from the message file.				
ERP LN	Field can be used as qualifier 2 on field tdsis312.stbp				

---

Position	11	Field Format	an..9	Field Status	M
<b>Field Name</b>	<b><u>Ship-from-BP / Ship-to-BP</u></b>		<b>Key field</b>		
Description	This position contains the code for the Ship-from / Ship-to Business Partner.				
Processing outgoing EDI Sub-System	None				
ERP LN	The Code for the ship-from Business Partner from ERP LN table field tdpur320.sfbp is converted using the conversion table ecedi463 or the constant "STBP" and the default Qualifier "ZZ", and it is mapped to this position.				
Processing Incoming EDI Sub-System	Transmission of the value from the message file.				
ERP LN	The Code for the Ship-To-Business Partner has to convert using the conversion table ecedi363 or the constant value "STBP" and Address Code ID given in ecedi224 = "ZZ", and it has to map to the EREP LN table field tds1s312.ofbp.				

Currently the incoming message MRL001 ignored the fields SA2 / 8 – SA2 / 11.

Position	12	Field Format	an..6	Field Status	M
<b>Field Name</b>	<b><u>Ship-To Address</u></b>		<b>Key field</b>		
Description	This field contains the ship-to address code.				
Processing outgoing EDI Sub-System	None				
ERP LN	The ship to address code from ERP LN table field tdpur320.stad is mapped to this position. Conversion table is ecedi463. If conversion not found then original value will be sent.				
Processing Incoming EDI Sub-System	Transmission of the value from the message file.				
ERP LN	It is mapped to tds1s312.stad. Conversion table is ecedi363. Position 18 is used as qualifier.				

Position	13	Field Format	n1	Field Status	M
<b>Field Name</b>	<b><u>Shipment or delivery based</u></b>		<b>Key field</b>		

Description This field identifies whether the goods need to be picked or delivered. Based on this value the delivery date of the goods will be calculated.

Processing outgoing  
EDI Sub-System None

ERP LN This field is mapped from the ERP LN table field ftdpur320.tqal to this position after conversion by the table Schedule type ecedi413. If conversion not found then the original value will be sent.

Processing Incoming  
EDI Sub-System Transmission of the value from the message file

ERP LN This field is mapped to table field tdsls312.sodb Conversion table is ecedi351. If conversion not found then error message is given.

Position	14	Field Format	an1	Field Status	M
<b>Field Name</b>	<b><u>Schedule Quantity Qualifier</u></b>		<b>Key field</b>		

Description This field identifies the quantity qualifier of the schedule. It communicates whether the quantity is cumulative or discrete.

Processing outgoing  
EDI Sub-System None

ERP LN This field will be filled with the constant value 'A' (actual values = discrete).

Processing Incoming  
EDI Sub-System Transmission of the value from the message file

ERP LN This field is mapped to table field tdsls312.qqal. Conversion table is ecedi352. If conversion not found then error message is given. Constant values 'A' and 'C' (cumulative) are allowed values.

---

Position	15	Field Format	n..22	Field Status	C
<b>Field Name</b>	<b><u>Forecast Horizon Start Date</u></b>		<b>Key field</b>		

Description This field identifies the start date for the requirements under release

Processing outgoing  
EDI Sub-System None

ERP LN This field is mapped from the ERP LN table field tdpur320.fohs to this position.

Processing Incoming  
EDI Sub-System Transmission of the value from the message file

ERP LN This field is mapped to table field tds1s312.fohs

Position	16	Field Format	n..22	Field Status	C
<b>Field Name</b>	<b><u>Forecast Horizon End Date</u></b>		<b>Key field</b>		

Description This field identifies the end date for the requirements under release

Processing outgoing  
EDI Sub-System None

ERP LN This field is mapped from the ERP LN table field tdpur320.fohe to this position.

Processing Incoming  
EDI Sub-System Transmission of the value from the message file

ERP LN This field is mapped to table field tds1s312.fohe

Position	17	Field Format	n..22	Field Status	M
<b>Field Name</b>	<b><u>Generation Date</u></b>		<b>Key field</b>		

Description This field identifies the release generation date

Processing outgoing  
EDI Sub-System None

ERP LN This field is mapped from the ERP LN table field tdpur320.egdt to this position.

Processing Incoming  
EDI Sub-System Transmission of the value from the message file

ERP LN This field is mapped to table field tds1s312.egdt

Position	18	Field Format	an..6	Field Status	M
Field Name	<u>Qualifier Address Code</u>		Key field		

Description This position is used to store the default qualifier 1 for the Address code which is defined in the message definition. It can be used to identify the sender, ship-to warehouse and ship-to address.

Processing outgoing  
EDI Sub-System None

ERP LN "ZZ"

Processing Incoming  
EDI Sub-System

ERP LN This field will be filled with the constant value "ZZ".  
The field can be used as (first) qualifier on field  
tdsls312.ofbp (pos. 3); tdsls312.stad (pos. 12); tdsls312.stbp (pos. 19)

Position	19	Field Format	an..6	Field Status	M
Field Name	<u>Warehouse / Ship-To BP</u>		Key field		

Description This field contains the ship-to address code.

Processing outgoing  
EDI Sub-System None

ERP LN The ship to address code from ERP LN table field tdpur320.cwar is mapped to this position. Conversion table is ecedi462.

Processing Incoming  
EDI Sub-System Transmission of the value from the message file.

ERP LN It is mapped to tdsls312.stbp. Conversion table is ecedi328. Position 18 is used as qualifier 1.

---

Position	20	Field Format	an7	Field Status	M
<b>Field Name</b>	<b><u>Data Record end sign</u></b>				
Description	This field identifies the end of data record in the message block. It contains the constant value 'SA2_END'.				
Processing outgoing EDI Sub-System					
ERP LN	This field will be filled with the constant value 'SA2_END'.				
Processing Incoming EDI Sub-System	This field will be filled with the constant value 'SA2_END'.				
ERP LN	None				

## SA3 Schedule Header

Status: Mandatory

Frequency: Multiple by Release

Description: This data record contains all information of the Schedule Header except of text data, and it is related to SA2.

MRL In-house Format					Mapping from Application Table Fields (out)		Mapping to Application Table Fields (in)	
Pos	Field Description	Key	ST	FM	Table field	Action	Table field	Action
1	Kind of data record	O/I	M	an3	SA3		SA3	
2	Message Reference	O/I	M	an..35	ecedi701.bano	Generation (see below)	ecedi702.bano	Generation by EDI Sub-System
3	(Net) ID of Sender	O/I	M	an..17	ecedi020.neta	Conversion (see below)	tdsls312.ofbp	Conversion (see below)
4	Release No.	O/I	M	an..9	tdpur320.rlna		tdsls312.crln	
5	Release Revision	O/I	M	n..4	tdpur320.rlv		tdsls312.crlr	
6	Release Position		M	an..6	tdpur321.rpon		tdsls308.cpon	
7	Original Schedule Number		M	an..9	tdpur321.schn		tdsls307.cchn	
8	Ship-from BP / WH		M	an..9	tdpur310.sfbp	Conversion	tdsls307.cwar	Conversion
9	Warehouse / Ship-to BP		M	an..9	tdpur310.cwar		tdsls311.stbp	Conversion
10	Item		M	an..47	tdpur310.item	Conversion	tdsls311.item	Conversion
11	Ship-to-Address		M	an..6	tdpur320.stad	Conversion	tdsls311.stad	Conversion
12	Qualifier Delivery Point		M	an..2	"DP"			
13	Buy-from BP / Sales Office		M	an..9	tdpur310.bfbp	Conversion	tdsls311.cofc	Conversion



MRL In-house Format					Mapping from Application Table Fields (out)		Mapping to Application Table Fields (in)	
Pos	Field Description	Key	ST	FM	Table field	Action	Table field	Action
14								
15	Contract number		C	an..9	tdpur310.cono			
16	Contract Position		C	n..2	tdpur310.pono			
17	Purchase Office		M	an..6	tdpur310.cofc	Conversion		
18	Inventory Unit		M	an..3	tcibd001.cuni	Conversion		
19	Last ASN creation date		C	n..22	whinh300.acdt			
20	Last BP's ASN		M	an..9	tdpur321.lasn		tdsls311.lasn	
21	Last Receipt date		M	n..22	tdpur321.lrdt		tdsls311.lrdt	
22	Last Receipt quantity		M	n..19	tdpur321.qilr		tdsls311.qilr	
23	Last Packing Slip		M	an..30	tdpur321.dino		tdsls311.lsid	
24	Receipt CUM		M	n..19	tdpur321.qicr		tdsls311.qicr	
25								
26	Prior required CUM		C	n..19	tdpur321.qicp		tdsls311.qicp	
27								
28	Sipped CUM		C	n..19	tdpur321.qics			
29	Engineering Item Revision		C	an..9	tdpur310.revi		tdsls311.revi	
30	Qualifier Address Code		M	an..6	"ZZ"		"ZZ"	
31	Qualifier Item Code		M	an..6	"SA"		"SA"	
32	Qualifier BP		M	an..6	"STBP"		"STBP"	
33	Contract Office		C	an..6	tdpur310.ccof			
34	Tax country		M	an..3	tdpur321.ccty	Conversion	tdsls307.ccty	Conversion
35	Tax Code		M	an..9	tdpur321.cvat	Conversion	tdsls307.cvat	Conversion
36	Exempt Reason		C	an..6	tdpur321.rcod	Conversion	tdsls307.rcod	Conversion

MRL In-house Format					Mapping from Application Table Fields (out)		Mapping to Application Table Fields (in)	
Pos	Field Description	Key	ST	FM	Table field	Action	Table field	Action
37	Exempt certificate		C	an..20	tdpur321.ceno		tdsls307.ceno	
38	Exempt		C	an..6	tdpur321.exmt		tdsls307.exmt	
39	BP Tax Country		M	an..3	tdpur321.bptc	Conversion	tdsls307.bptc	Conversion
40	Data Record End Sign	O/I	M	an7	SA3_END		SA3_END	

Detailed description:

Material Release

Kind of data record:

SA3 Schedule Header

Position	1	Field Format	an3	Field Status	M
Field Name	<u>Kind of Data Record</u>		Key field Out / IN		

Description This field identifies the kind of data record in the message block. It contains the constant value 'SA3'.

Processing outgoing  
EDI Sub-System

ERP LN This field will be filled with the constant value 'SA3'.

Processing Incoming  
EDI Sub-System

This field will be filled with the constant value 'SA3'.

ERP LN None

---

Position	2	Field Format	an..35	Field Status	M
Field Name	<u>Message Reference</u>		Key field Out / IN		

Description This field identifies all connected data records of one Material Release. The numbering, which has to be clear by MRL, helps to control the chronological order of the Material Releases and the complete transmission.

Processing outgoing  
EDI Sub-System

ERP LN Analogously to data record SA2

Processing Incoming  
EDI Sub-System

ERP LN Analogously to data record SA2

Position	3	Field Format	an..17	Field Status	M
Field Name	<u>(Net) ID of sender</u>		Key field Out / IN		

Description This field contains the identification of the sender (for example the ILN Number)

Processing outgoing  
EDI Sub-System

Transmission of the value from the message file.

ERP LN The identification is stored in the ERP LN table ecedi020 'Our Identification' under the corresponding network in the ERP LN table field ecedi020.neta. The contents of this field are mapped to the position of the transmission file. Here you can store the general ILN-Number for your customer.

Processing Incoming  
EDI Sub-System

ERP LN The identification of the sender determines the corresponding business partner (customer) and the network in the table ecedi028 'Relations by network'. This identification is mapped to the ERP LN table field tds1s312.ofbp. Pos. 18 is used as first qualifier, pos. 8 as second qualifier.

Position	4	Field Format	an..9	Field Status	M
Field Name	<u>Release Number</u>		Key field Out / IN		
Description	This field contains the origin Release Number of the related schedules.				
Processing outgoing EDI Sub-System	None				
ERP LN	The Release number is mapped from ERP LN table field tdpur320.rln0 to this position.				
Processing Incoming EDI Sub-System	Transmission of the value from the message file.				
ERP LN	Mapping to ERP LN table field tds1s312.crln; the customer release				

Position	5	Field Format	n..4	Field Status	M
Field Name	<u>Release Revision Number</u>		Key field Out / In		
Description	This field contains the Release Revision Number.				
Processing outgoing EDI Sub-System	None				
ERP LN	The Release number is mapped from ERP LN table field tdpur320.rlv0 to this position.				
Processing Incoming EDI Sub-System	Transmission of the value from the message file.				
ERP LN	Mapping to ERP LN table field tds1s312.crlr; customer's release revision.				

---

Position	6	Field Format	n..4	Field Status	M
<b>Field Name</b>	<b><u>Release Position</u></b>				

Description This field contains the Release Position.

Processing outgoing  
EDI Sub-System None

ERP LN The release position is mapped from the ERP LN table field tdpur321.rpon to this position

Processing Incoming  
EDI Sub-System Transmission of the value from the message file.

ERP LN It is mapped to field tdsls308.cpon

Position	7	Field Format	an..9	Field Status	M
<b>Field Name</b>	<b><u>Schedule Number</u></b>				

Description This position contains the original Schedule Number

Processing outgoing  
EDI Sub-System None

ERP LN The schedule number is mapped from the ERP LN table field tdpur310.schn to this position.

Processing Incoming  
EDI Sub-System Transmission of the value from the message file.

ERP LN Mapped to table field tdsls307.cchn

Position	8	Field Format	an..9	Field Status	M
<b>Field Name</b>	<b><u>Ship-from-BP / Warehouse</u></b>				
Description	This position contains the code for the Ship-from Business Partner who will deliver the goods.				
Processing outgoing EDI Sub-System	None				
ERP LN	The Code for the ship-from Business Partner from ERP LN table field tdpur310.sfbp is converted using the conversion table ecedi463 or the constant "STBP" and the default Qualifier "ZZ". If no conversion is found the original value is mapped to this position.				
Processing Incoming EDI Sub-System	Transmission of the value from the message file.				
ERP LN	The value has to map to the ERP LN table field tdsls307.cwar after conversion by table ecedi355 and Address Code ID given in ecedi224 = "ZZ".				

Position	9	Field Format	an..9	Field Status	M
<b>Field Name</b>	<b><u>Warehouse / Ship-to BP</u></b>				
Description	This field contains the warehouse (respective BP) code which expects the good's receipt.				
Processing outgoing EDI Sub-System	None				
ERP LN	The ship to address code from ERP LN table field tdpur310.cwar is mapped to this position. Conversion table is ecedi462.				
Processing Incoming EDI Sub-System	Transmission of the value from the message file.				
ERP LN	It is mapped to tdsls311.stbp. Conversion table is ecedi328. Position 30 is used as qualifier 1.				

---

Position	10	Field Format	an..47	Field Status	M
<b>Field Name</b>	<b><u>Item</u></b>				

Description	This field contains the item code.
Processing outgoing EDI Sub-System	None
ERP LN	The item code from ERP LN table field tdpur310.item is mapped to this position.
Processing Incoming EDI Sub-System	Transmission of the value from the message file
ERP LN	Mapped to table field tds1s311.item after conversion with qualifier 'SA'. Position 31 is used as qualifier

Position	11	Field Format	an..6	Field Status	M
<b>Field Name</b>	<b><u>Ship-to Address</u></b>				

Description	This field contains the ship-to address code referring to the warehouse which expects the good's receipt.
Processing outgoing EDI Sub-System	None
ERP LN	The ship to address code from ERP LN table field tdpur310.stad is mapped to this position. Conversion table is ecedi463.
Processing Incoming EDI Sub-System	Transmission of the value from the message file.
ERP LN	It is mapped to tds1s311.stad. Conversion table is ecedi363. Position 30 is used as qualifier 1.

Position	12	Field Format	an..2	Field Status	M
<b>Field Name</b>	<b><u>Qualifier Delivery Point</u></b>				

Description This field contains the qualifier which identifies the Delivery Point of position 11.

Processing outgoing  
EDI Sub-System None

ERP LN The value 'DP' is filled in this position

Processing Incoming  
EDI Sub-System Transmission of the value from the message file.

ERP LN N. A.

Position	13	Field Format	an..9	Field Status	M
<b>Field Name</b>	<b><u>Buy-from BP / Sales Office</u></b>				

Description This field identifies the Buy-from BP who will deliver the goods or the responsible Sales Office to deliver the goods.

Processing outgoing  
EDI Sub-System None

ERP LN This field is mapped from the ERP LN table field tdpur310.bfbp to this position and converted using the table ecedi468. If conversion not found then the original value will be sent.

Processing Incoming  
EDI Sub-System Transmission of the value from the message file

ERP LN The position is mapped to tdsis311.cofc after conversion using the table ecedi350. If conversion not found then the default sales office is filled either from Sold-to BP or user profiles.

---



Position	15	Field Format	an..9	Field Status	C
<b>Field Name</b>	<b><u>Contract Number</u></b>				

Description This field contains the contract number.

Processing outgoing  
EDI Sub-System None

ERP LN This field is mapped from the ERP LN table field tdpur310.cono to this position.

Processing Incoming  
EDI Sub-System  
ERP LN

Position	16	Field Format	n2	Field Status	C
<b>Field Name</b>	<b><u>Contract Position</u></b>				

Description This field contains the contract position number.

Processing outgoing  
EDI Sub-System None

ERP LN This field is mapped from the ERP LN table field tdpur310.pono to this position.

Processing Incoming  
EDI Sub-System  
ERP LN

Position	17	Field Format	an..9	Field Status	C
<b>Field Name</b>	<b><u>Purchase Office</u></b>				

Description This field identifies the responsible Purchase Office.

Processing outgoing  
EDI Sub-System None

ERP LN This field is mapped from the ERP LN table field tdpur310.cofc to this position and converted using the table ecedi420. If conversion not found then the original value will be sent.

Processing Incoming  
EDI Sub-System  
ERP LN N. A.

Position	18	Field Format	an..3	Field Status	M
<b>Field Name</b>	<b><u>Inventory Unit</u></b>				

Description This field identifies the inventory unit of the item

Processing outgoing  
EDI Sub-System None

ERP LN This field is mapped from the ERP LN table field tcibd001.cuni to this position after conversion by table ecedi442. If conversion not found then original value will be sent.

Processing Incoming  
EDI Sub-System

ERP LN N. A.

Position	19	Field Format	n..22	Field Status	C
<b>Field Name</b>	<b><u>Last ASN Creation Date</u></b>				

Description This field includes the last supplier's Advance Shipping Notice creation date.

Processing outgoing  
EDI Sub-System None

ERP LN This field has to be taken from warehouse depending on the ASN number, it mapped to whinh300.acdt.

Processing Incoming  
EDI Sub-System

ERP LN N. A.

---

Position	20	Field Format	an..9	Field Status	M
<b>Field Name</b>	<b><u>Last Supplier's ASN</u></b>				

Description This field includes the last supplier's Advance Shipping Notice Number.

Processing outgoing  
EDI Sub-System

None

ERP LN

This field is mapped from the ERP LN table field tdpur321.lasn to this position.

Processing Incoming  
EDI Sub-System

Transmission of the value from the message file

ERP LN

Mapped to table field tds1s311.lasn

Position	21	Field Format	n..22	Field Status	M
<b>Field Name</b>	<b><u>Last Receipt Date</u></b>				

Description This field includes the last good's receipt date

Processing outgoing  
EDI Sub-System

None

ERP LN

This field is mapped from the ERP LN table field tdpur321.lrdt to this position.

Processing Incoming  
EDI Sub-System

Transmission of the value from the message file

ERP LN

Mapped to table field tds1s311.lrdt

Position	22	Field Format	n..19	Field Status	M
<b>Field Name</b>	<b><u>Last Receipt Quantity</u></b>				

Description This field includes the last receipt quantity referring to the last date.

Processing outgoing  
EDI Sub-System

None

ERP LN

This field is mapped from the ERP LN table field tdpur321.qilr to this position.

Processing Incoming  
EDI Sub-System

Transmission of the value from the message file

ERP LN

Mapped to table field tds1s311.qilr

Position	23	Field Format	an..30	Field Status	M
<b>Field Name</b>	<b><u>Last Packing Slip No.</u></b>				

Description This field identifies the last supplier's shipment.

Processing outgoing  
EDI Sub-System None

ERP LN This field is mapped from the ERP LN table field tdpur321.dino to this position.

Processing Incoming  
EDI Sub-System Transmission of the value from the message file

ERP LN Mapped to table field tds1s311.Isid

Position	24	Field Format	n..19	Field Status	M
<b>Field Name</b>	<b><u>CUM Received</u></b>				

Description This field includes the receipt cumulative quantity.

Processing outgoing  
EDI Sub-System None

ERP LN This field is mapped from the ERP LN table field tdpur321.qicr to this position.

Processing Incoming  
EDI Sub-System Transmission of the value from the message file

ERP LN Mapped to table field tds1s311.qicr

Position	26	Field Format	n..19	Field Status	C
<b>Field Name</b>	<b><u>Prior required CUM</u></b>				

Description This field includes the prior required cumulative quantity.

Processing outgoing  
EDI Sub-System None

ERP LN This field is mapped from the ERP LN table field tdpur321.qicp to this position.

Processing Incoming  
EDI Sub-System Transmission of the value from the message file

ERP LN Mapped to table field tds1s311.qicp

---

Position	28	Field Format	n..19	Field Status	C
<b>Field Name</b>	<b><u>CUM Shipped</u></b>				

Description This field includes the already shipped cumulative.

Processing outgoing  
EDI Sub-System None

ERP LN This field is mapped from the ERP LN table field tdpur321.qics to this position.

Processing Incoming  
EDI Sub-System Transmission of the value from the message file

ERP LN Mapped to table field tdsis311.qics

Position	29	Field Format	n..6	Field Status	C
<b>Field Name</b>	<b><u>Engineering item revision</u></b>				

Description This field identifies the engineering revision of the item.

Processing outgoing  
EDI Sub-System None

ERP LN This field is mapped from the ERP LN table field tdpur310.revi to this position.

Processing Incoming  
EDI Sub-System Transmission of the value from the message file

ERP LN Mapped to table field tdsis311.revi

Position	30	Field Format	an..6	Field Status	M
<b>Field Name</b>	<b><u>Qualifier Address Code</u></b>				
Description	This position is used to store the default qualifier 1 for the Address code which is defined in the message definition. It can be used to identify the sender, ship-to warehouse and ship-to address.				
Processing outgoing EDI Sub-System	None				
ERP LN	"ZZ"				
Processing Incoming EDI Sub-System					
ERP LN	This field will be filled with the constant value "ZZ". The field can be used as (first) qualifier on field tdsls312.ofbp (pos. 3); tdsls307.cwar (pos. 8); tdsls311.stbp (pos. 9)				

Position	31	Field Format	an..6	Field Status	M
<b>Field Name</b>	<b><u>Qualifier Item Code</u></b>				
Description	This field contains the qualifier that can be used to identify the item. It will be filled with the constant value "SA"				
Processing outgoing EDI Sub-System	None				
ERP LN	"SA"				
Processing Incoming EDI Sub-System					
ERP LN	This field will be filled with the constant value "SA".				

---

Position	32	Field Format	an..6	Field Status	M
<b>Field Name</b>	<b><u>Qualifier Ship-to-BP</u></b>				

Description This position contains the qualifier to identify the Business partner.

Processing outgoing  
EDI Sub-System None

ERP LN This field will be filled with the constant value "STBP"

Processing Incoming  
EDI Sub-System Transmission of the value from the message file.

ERP LN Field can be used as qualifier 2 on field tdsIs311.stbp

Position	33	Field Format	an..6	Field Status	C
<b>Field Name</b>	<b><u>Contract Office</u></b>				

Description This position contains the purchase office linked to the contract position.

Processing outgoing  
EDI Sub-System None

ERP LN This field will be mapped from the ERP LN table field tdpur310.ccof

Processing Incoming  
EDI Sub-System

ERP LN N. A.

Position	34	Field Format	an..3	Field Status	M
<b>Field Name</b>	<b><u>Tax Country</u></b>				

Description This field contains the country code which is linked to the tax code.

Processing outgoing  
EDI Sub-System None

ERP LN The tax country code is mapped from ERP LN table field tdpur321.ccty to this position after conversion with ERP LN table ecedi440.

Processing Incoming  
EDI Sub-System Transmission of the value from the message file.

ERP LN Mapping to the ERP LN table field tdsIs307.ccty after conversion with ERP LN table ecedi302.

Position	35	Field Format	an..9	Field Status	M
<b>Field Name</b>	<b><u>Tax Code</u></b>				
Description	This field identifies the tax code.				
Processing outgoing EDI Sub-System	None				
ERP LN	The tax code is mapped from ERP LN table field tdpur321.cvat to this position after conversion by ERP LN table ecedi446.				
Processing Incoming EDI Sub-System	Transmission of the value from the message file.				
ERP LN	Mapping to the ERP LN table field tdsis307.cvat after conversion by table ecedi308.				

Position	36	Field Format	an..6	Field Status	C
<b>Field Name</b>	<b><u>Exempt Reason</u></b>				
Description	This field contains the tax exempt reason code.				
Processing outgoing EDI Sub-System	None				
ERP LN	The exempt reason is mapped from ERP LN table field tdpur321.rcod to this position after conversion with ERP LN table ecedi495.				
Processing Incoming EDI Sub-System	Transmission of the value from the message file.				
ERP LN	Mapping to the ERP LN table field tdsis307.rdoc after conversion with ERP LN table ecedi353.				

---



Position	37	Field Format	an..20	Field Status	C
<b>Field Name</b>	<b><u>Exempt certificate</u></b>				

Description This field contains the tax exempt certificate number.

Processing outgoing  
EDI Sub-System None

ERP LN The exempt certificate is mapped from ERP LN table field tdpur321.ceno to this position.

Processing Incoming  
EDI Sub-System Transmission of the value from the message file.

ERP LN Mapping to the ERP LN table field tdsls307.ceno

Position	38	Field Format	an..6	Field Status	C
<b>Field Name</b>	<b><u>Exempt</u></b>				

Description This field contains a qualifier if tax exemption applies or not.

Processing outgoing  
EDI Sub-System

ERP LN The exempt qualifier from ERP LN table field tdpur321.exmt is mapped to this position.

Processing Incoming  
EDI Sub-System Transmission of the value from the message file.

ERP LN Mapping to the ERP LN table field tdsls307.exmt.

Position	39	Field Format	an..3	Field Status	M
<b>Field Name</b>	<b><u>BP Tax Country</u></b>				

Description This field contains the tax country code of the Business Partner.

Processing outgoing  
EDI Sub-System None

ERP LN The business partner tax country code is mapped from ERP LN table tdpur321.bptc to this position after conversion with ERP LN table ecedi468.

Processing Incoming  
EDI Sub-System Transmission of the value from the message file.

ERP LN Mapping to the ERP LN table field tds1s307.bptc after conversion with ERP LN table ecedi328.

Position	40	Field Format	an7	Field Status	M
<b>Field Name</b>	<b><u>Data Record end sign</u></b>				

Description This field identifies the end of data record in the message block. It contains the constant value 'SA3\_END'.

Processing outgoing  
EDI Sub-System

ERP LN This field will be filled with the constant value 'SA3\_END'.

Processing Incoming  
EDI Sub-System This field will be filled with the constant value 'SA3\_END'.

ERP LN None

---

## SA4 Schedule Header Text

Status: Conditional  
 Frequency: Once by Release Position  
 Description: This data record contains the text information of the Schedule Header and is related to SA3.

MRL In-house Format					Mapping from Application Table Fields (out)		Mapping to Application Table Fields (in)	
Pos	Field Description	Key	ST	FM	Table field	Action	Table field	Action
1	Kind of data record	O/I	M	an3	SA4		SA4	
2	Message Reference	O/I	M	an..35	ecedi701.bano	Generation (see below)	ecedi702.bano	Generation by EDI Sub-System
3	(Net) ID of Sender	O/I	M	an..17	ecedi020.neta	Conversion (see below)	tdsls312.ofbp	Conversion (see below)
4	Release No.	O/I	M	an..9	tdpur320.rln		tdsls312.crln	
5	Release revision	O/I	M	n..4	tdpur320.rlv		tdsls312.crlr	
6	Release Position	O/I	M	an..6	tdpur321.rpon		tdsls308.cpon	
7	Original Schedule Number	O/I	M	an..9	tdpur321.schn		tdsls307.cchn	
8	Header text 1		C	an..70	tdpur310.txta		tdsls311.txta	
9	Header text 2		C	an..70			tdsls311.txta	
10	Header text 3		C	an..70			tdsls311.txta	
11	Data Record End Sign	O/I	M	an7	SA4_END		SA4_END	

Detailed description: Material Release  
 Kind of data record: SA4 Schedule Header Text

Position	1	Field Format	an3	Field Status	M
Field Name	<u>Kind of Data Record</u>		Key field Out / IN		
Description	This field identifies the kind of data record in the message block. It contains the constant value 'SA4'.				
Processing outgoing EDI Sub-System					
ERP LN	This field will be filled with the constant value 'SA4'.				
Processing Incoming EDI Sub-System	This field will be filled with the constant value 'SA4'.				
ERP LN	None				

Position	2	Field Format	an..35	Field Status	M
Field Name	<u>Message Reference</u>		Key field Out / IN		
Description	This field identifies all connected data records of one Material Release. The numbering, which has to be clear by MRL, helps to control the chronological order of the MRL and the complete transmission.				
Processing outgoing EDI Sub-System					
ERP LN	Refer to data record SA2				
Processing Incoming EDI Sub-System					
ERP LN	Refer to data record SA2				

---

Position	3	Field Format	an..17	Field Status	M
Field Name	<u>(Net) ID of sender</u>		Key field Out / IN		
Description	This field contains the identification of the sender (for example the ILN Number)				
Processing outgoing EDI Sub-System	Transmission of the value from the message file.				
ERP LN	Refer to data record SA2				
Processing Incoming EDI Sub-System					
ERP LN	Refer to data record SA2				

Position	4	Field Format	an..9	Field Status	M
Field Name	<u>Release Number</u>		Key field Out / IN		
Description	This field contains the origin Release Number of the related schedules.				
Processing outgoing EDI Sub-System	None				
ERP LN	The Release number is mapped from ERP LN table field tdpur320.rln to this position.				
Processing Incoming EDI Sub-System	Transmission of the value from the message file.				
ERP LN	Mapping to ERP LN table field tdsIs312.crln; the customer release				

Position	5	Field Format	n..4	Field Status	M
Field Name	<u>Release Revision Number</u>		Key field	Out / IN	
Description	This field contains the Release Revision Number.				
Processing outgoing EDI Sub-System	None				
ERP LN	The Revision number is mapped from ERP LN table field tdpur320.rlv to this position.				
Processing Incoming EDI Sub-System	Transmission of the value from the message file.				
ERP LN	Mapping to ERP LN table field tdsls312.crlr; customer's release revision.				

Position	6	Field Format	n..4	Field Status	M
Field Name	<u>Release Position</u>		Key field	Out / IN	
Description	This field contains the Release Position.				
Processing outgoing EDI Sub-System	None				
ERP LN	The release position is mapped from the ERP LN table field tdpur321.rpon to this position				
Processing Incoming EDI Sub-System	Transmission of the value from the message file.				
ERP LN	It is mapped to field tdsls308.cpon				

Position	7	Field Format	an..9	Field Status	M
Field Name	<u>Schedule Number</u>		Key field	Out / IN	
Description	This position contains the original Schedule Number				
Processing outgoing EDI Sub-System	None				
ERP LN	The schedule number is mapped from the ERP LN table field tdpur310.schn to this position.				
Processing Incoming EDI Sub-System	Transmission of the value from the message file.				
ERP LN	Mapped to table field tdsls307.cchn				

---

Position	8	Field Format	an..70	Field Status	C
<b>Field Name</b>	<b><u>Schedule Header Text 1</u></b>				
Description	This field contains a free text 1 with a maximum of 70 characters.				
Processing outgoing EDI Sub-System					
ERP LN	Mapping of ERP LN table field tdpur310.txta to position.				
Processing Incoming EDI Sub-System	Transmission of the value from the transmission file.				
ERP LN	Mapping to ERP LN table field tdsls400.txta				

Position	9	Field Format	an..70	Field Status	C
<b>Field Name</b>	<b><u>Schedule Header Text 2</u></b>				
Description	This field contains a free text 2 with a maximum of 70 characters.				
Processing outgoing EDI Sub-System					
ERP LN	None				
Processing Incoming EDI Sub-System	Transmission of the value from the transmission file.				
ERP LN	Mapping to ERP LN table field tdsls311.txta				

Position	10	Field Format	an..70	Field Status	C
<b>Field Name</b>	<b><u>Schedule Header Text 3</u></b>				
Description	This field contains a free text 3 with a maximum of 70 characters.				
Processing outgoing EDI Sub-System					
ERP LN	None				
Processing Incoming EDI Sub-System	Transmission of the value from the transmission file.				
ERP LN	Mapping to ERP LN table field tdsls311.txta				

Position	11	Field Format	an7	Field Status	M
Field Name	<u>Data Record end sign</u>		Key field Out / IN		
Description	This field identifies the end of data record in the message block. It contains the constant value 'SA4_END'.				
Processing outgoing EDI Sub-System					
ERP LN	This field will be filled with the constant value 'SA4_END'.				
Processing Incoming EDI Sub-System	This field will be filled with the constant value 'SA4_END'.				
ERP LN	None				



## SA5 Schedule Authorizations

**Status:** Mandatory  
**Frequency:** Once by Release Position  
**Description:** This data record contains the information about the authorizations and is related to SA3.

MRL In-house Format					Mapping from Application Table Fields (out)		Mapping to Application Table Fields (in)	
Pos	Field Description	Key	ST	FM	Table field	Action	Table field	Action
1	Kind of data record	O/I	M	an3	SA5		SA5	
2	Message Reference	O/I	M	an..35	ecedi701.bano	Generation (see below)	ecedi702.bano	Generation by EDI Sub-System
3	Net ID of Sender	O/I	M	an..17	ecedi020.neta	Conversion (see below)	ecedi702.bpid	Conversion (see below)
4	Release No.	O/I	M	an..9	tdpur320.rlno		tdsls312.crln	
5	Release revision	O/I	M	n..4	tdpur320.rlv		tdsls312.crlr	
6	Release Position	O/I	M	an..6	tdpur321.rpon		tdsls308.cpon	
7	Original Schedule Number	O/I	M	an..9	tdpur321.schn		tdsls307.cchn	
8	FAB Period		C	n..3	tdpur302.tifa			
9	RAW period		C	n..3	tdpur302.tira			
10	CUM Start date		C	n..22	tdpur321.csdt		tdsls311.csdt	
11	FAB Authorization		C	n..19	tdpur321.qifa		tdsls311.qifa	
12	RAW Authorization		C	n..19	tdpur321.qira		tdsls311.qira	
13	FAB Auth. Through Date		C	n..22	tdpur321.fedt		tdsls311.edfb	

MRL In-house Format					Mapping from Application Table Fields (out)		Mapping to Application Table Fields (in)	
Pos	Field Description	Key	ST	FM	Table field	Action	Table field	Action
14	RAW Auth. Through Date		C	n..22	tdpur321.redt		tdsls311.edrw	
15	Data Record End Sign	O/I	M	an..7	"SA5_END"		"SA5_END"	

Detailed description: Material Release

Kind of data record: SA5 Schedule Authorization

Position	1	Field Format	an3	Field Status	M
Field Name	<u>Kind of Data Record</u>		Key field Out / IN		

Description This field identifies the kind of data record in the message block. It contains the constant value 'SA5'.

Processing outgoing  
EDI Sub-System

ERP LN This field will be filled with the constant value 'SA5'.

Processing Incoming  
EDI Sub-System

This field will be filled with the constant value 'SA5'.

ERP LN None

---

Position	2	Field Format	an..35	Field Status	M
Field Name	<u>Message Reference</u>		Key field Out / IN		

Description This field identifies all connected data records of one Material Release. The numbering, which has to be clear by MRL, helps to control the chronological order of the MRL and the complete transmission.

Processing outgoing  
EDI Sub-System

ERP LN Refer to data record SA3

Processing Incoming  
EDI Sub-System

ERP LN Refer to data record SA3

Position	3	Field Format	an..17	Field Status	M
Field Name	<u>(Net) ID of sender</u>		Key field Out / IN		

Description This field contains the identification of the sender (for example the ILN Number)

Processing outgoing  
EDI Sub-System Transmission of the value from the message file.

ERP LN Refers to data record SA3

Processing Incoming  
EDI Sub-System

ERP LN Refers to data record SA3

Position	4	Field Format	an..9	Field Status	M
Field Name	<u>Release Number</u>		Key field Out / IN		

Description This field contains the origin Release Number of the related schedules.

Processing outgoing  
EDI Sub-System None

ERP LN Refers to data record SA3

Processing Incoming  
EDI Sub-System

ERP LN Refers to data record SA3

Position	5	Field Format	n..4	Field Status	M
Field Name	<u>Release Revision Number</u>		Key field Out / IN		
Description	This field contains the Release Revision Number.				
Processing outgoing EDI Sub-System	None				
ERP LN	Refers to data record SA3				
Processing Incoming EDI Sub-System					
ERP LN	Refers to data record SA3				

Position	6	Field Format	n..6	Field Status	M
Field Name	<u>Release Position</u>		Key field Out / IN		
Description	This field contains the Release Position.				
Processing outgoing EDI Sub-System	None				
ERP LN	The release position is mapped from the ERP LN table field tdpur321.rpon to this position				
Processing Incoming EDI Sub-System	Transmission of the value from the message file.				
ERP LN	It is mapped to field tdsls308.cpon				

Position	7	Field Format	an..9	Field Status	M
Field Name	<u>Schedule Number</u>		Key field Out / In		
Description	This position contains the original Schedule Number				
Processing outgoing EDI Sub-System	None				
ERP LN	The schedule number is mapped from the ERP LN table field tdpur310.schn to this position.				
Processing Incoming EDI Sub-System	Transmission of the value from the message file.				
ERP LN	Mapped to table field tdsls307.cchn				

---

Position	8	Field Format	n..3	Field Status	C
<b>Field Name</b>	<b><u>FAB Period</u></b>				

Description This field identifies the FAB authorization period.

Processing outgoing  
EDI Sub-System None

ERP LN This field is mapped from the ERP LN table field tdpur302.tifa to this position. If contract is not linked to a schedule then this field is mapped from ERP LN table field tdipu010.tifa

Processing Incoming  
EDI Sub-System

ERP LN N. A.

Position	9	Field Format	n..3	Field Status	C
<b>Field Name</b>	<b><u>RAW Period</u></b>				

Description This field identifies the FAB authorization period.

Processing outgoing  
EDI Sub-System None

ERP LN This field is mapped from the ERP LN table field tdpur302.tira to this position. If contract is not linked to a schedule then this field is mapped from ERP LN table field tdipu010.tira

Processing Incoming  
EDI Sub-System

ERP LN N. A.

Position	10	Field Format	n..22	Field Status	C
<b>Field Name</b>	<b><u>CUM Start Date</u></b>				

Description This field includes the CUM Start date.

Processing outgoing  
EDI Sub-System None

ERP LN This field is mapped from the ERP LN table tdpur321.csdt is mapped to this position.

Processing Incoming  
EDI Sub-System Transmission of the value from the message file

ERP LN Mapped to table field tdsIs311.csdt.

Position	11	Field Format	n..19	Field Status	C
<b>Field Name</b>	<b><u>FAB Authorization</u></b>				

Description	This field includes the FAB authorized quantity
Processing outgoing EDI Sub-System	None
ERP LN	This field is mapped from the ERP LN table tdpur321.qifa is mapped to this position.
Processing Incoming EDI Sub-System	Transmission of the value from the message file
ERP LN	Mapped to table field tds1s311.qifa.

Position	12	Field Format	n..19	Field Status	C
<b>Field Name</b>	<b><u>RAW Authorization</u></b>				

Description	This field includes the RAW authorized quantity
Processing outgoing EDI Sub-System	None
ERP LN	This field is mapped from the ERP LN table tdpur321.qira is mapped to this position.
Processing Incoming EDI Sub-System	Transmission of the value from the message file
ERP LN	Mapped to table field tds1s311.qira.

Position	13	Field Format	n..22	Field Status	C
<b>Field Name</b>	<b><u>FAB Author. Through Date</u></b>				

Description	This field includes the FAB Authorization End Date.
Processing outgoing EDI Sub-System	None
ERP LN	This field is mapped from the ERP LN table tdpur321.fedt is mapped to this position.
Processing Incoming EDI Sub-System	Transmission of the value from the message file
ERP LN	Mapped to table field tds1s311.edfb.

Position	14	Field Format	n..22	Field Status	C
<b>Field Name</b>	<b><u>RAW Author. Through Date</u></b>				

Description	This field includes the RAW Authorization End Date.
Processing outgoing EDI Sub-System	None
ERP LN	This field is mapped from the ERP LN table tdpur321.redt is mapped to this position.
Processing Incoming EDI Sub-System	Transmission of the value from the message file
ERP LN	Mapped to table field tdsIs311.edrw.

Position	15	Field Format	an7	Field Status	M
<b>Field Name</b>	<b><u>Data Record end sign</u></b>		<b>Key field Out / IN</b>		

Description	This field identifies the end of data record in the message block. It contains the constant value 'SA5_END'.
Processing outgoing EDI Sub-System	
ERP LN	This field will be filled with the constant value 'SA5_END'.
Processing Incoming EDI Sub-System	This field will be filled with the constant value 'SA5_END'.
ERP LN	None

## SA6 Schedule Lines

Status: Mandatory

Frequency: Multiple by Release Position

Description: This data record contains the information about the Release Position Details including the Schedule Lines, and it is related to SA3.

MRL In-house Format					Mapping from Application Table Fields (out)		Mapping to Application Table Fields (in)	
Pos	Field Description	Key	ST	FM	Table field	Action	Table field	Action
1	Kind of data record	O/I	M	an3	SA6		SA6	
2	Message Reference	O/I	M	an..35	ecedi701.bano	Generation (see below)	ecedi702.bano	Generation by EDI Sub-System
3	Net ID of Sender	O/I	M	an..17	ecedi020.neta	Conversion (see below)	ecedi702.bpid	Conversion (see below)
4	Release No.	O/I	M	an..9	tdpur320.rln		tdsls312.crln	
5	Release revision	O/I	M	n..4	tdpur320.rlv		tdsls312.crlr	
6	Release Position	O/I	M	an..6	tdpur321.rpon		tdsls308.cpon	
7	Original Schedule Number	O/I	M	an..9	tdpur321.schn		tdsls307.cchn	
8	Release Position Detail		M	n..4	tdpur322.posd			
9	Schedule Position		M	n..4	tdpur322.spon		tdsls307.cchp	
10	Start Date		M	n..22	tdpur322.sdat		tdsls307.sdat	
11	End Date		M	n..22	tdpur322.sdat		tdsls307.edat	
12	Requirement Type		M	n..9	tdpur322.rqtp	Conversion	tdsls307.ctyp	Conversion



MRL In-house Format					Mapping from Application Table Fields (out)		Mapping to Application Table Fields (in)	
Pos	Field Description	Key	ST	FM	Table field	Action	Table field	Action
13								
14								
15	Qualifier Address Code		M	an..6	"ZZ"		"ZZ"	
16	Quantity		M	n..19	tdpur322.qoor		tdsls307.qoor	
17	Purchase / Sales Unit		M	an..3	tdpur322.cuqp	Conversion	tdsls307.cuqs	Conversion
18	Purchase / Sales price Unit		M	an..3	tdpur322.cupp	Conversion	tdsls307.cups	Conversion
19	Purchase / Sales price		M	n..19	tdpur322.pric		tdsls307.price	
20	Tax Country		M	an..3	tdpur322.ccty	Conversion	tdsls307.ccty	Conversion
21	Tax code		M	an..9	tdpur322.cvat	Conversion	tdsls307.cvat	Conversion
22	Exempt Reason		C	an..6	tdpur322.rcod	Conversion	tdsls307.rcod	Conversion
23	Exempt Certificate		C	an..20	tdpur322.ceno		tdsls307.ceno	
24	Length		C	n..8	tdpur322.leng		tdsls307.leng	
25	Width		C	n..8	tdpur322.widt		tdsls307.widt	
26	Height		C	n..8	tdpur322.thic		tdsls307.thic	
27	Time Unit		M	an..3	tdpur322.tiun		tdsls307.tiun	
28	Warehouse / Dock Location		M	an..6	tdpur322.cwar	Conversion	tdsls307.dock	Conversion
29	Reference ID		C	an..9	tdpur322.caid		tdsls307.refe	
30	Exempt		C	an..6	tdpur322.exmt		tdsls307.exmt	
31	BP Tax Country		M	an..3	tdpur322.bptc	Conversion	tdsls307.bptc	Conversion

MRL In-house Format					Mapping from Application Table Fields (out)		Mapping to Application Table Fields (in)	
Pos	Field Description	Key	ST	FM	Table field	Action	Table field	Action
32								
33								
34								
35	Manufacturer		C	an..6	tdpur322.cmnf			
36	Preferred Manufacturer		C	an..35	tdpur322.mpnr			
37	Data Record End Sign	O/I	M	an..7	"SA6_END"		"SA6_END"	

Detailed description:

Material Release

Kind of data record:

SA6 Release Position Detail

Position	1	Field Format	an3	Field Status	M
Field Name	<u>Kind of Data Record</u>		Key field Out / IN		

Description This field identifies the kind of data record in the message block. It contains the constant value 'SA6'.

Processing outgoing  
EDI Sub-System

ERP LN This field will be filled with the constant value 'SA6'.

Processing Incoming  
EDI Sub-System

This field will be filled with the constant value 'SA6'.

ERP LN

None

---

Position	2	Field Format	an..35	Field Status	M
Field Name	<u>Message Reference</u>		Key field Out / IN		

Description This field identifies all connected data records of one Material Release. The numbering, which has to be clear by MRL, helps to control the chronological order of the Material Releases and the complete transmission.

Processing outgoing  
EDI Sub-System

ERP LN Refer to data record SA3

Processing Incoming  
EDI Sub-System

ERP LN Refer to data record SA3

Position	3	Field Format	an..17	Field Status	M
Field Name	<u>(Net) ID of sender</u>		Key field Out / IN		

Description This field contains the identification of the sender (for example the ILN Number)

Processing outgoing  
EDI Sub-System Transmission of the value from the message file.

ERP LN Refers to data record SA3

Processing Incoming  
EDI Sub-System

ERP LN Refers to data record SA3

Position	4	Field Format	an..9	Field Status	M
Field Name	<u>Release Number</u>		Key field Out / IN		
Description	This field contains the origin Release Number of the related schedules.				
Processing outgoing EDI Sub-System	None				
ERP LN	Refers to data record SA3				
Processing Incoming EDI Sub-System					
ERP LN	Refers to data record SA3				

Position	5	Field Format	n..4	Field Status	M
Field Name	<u>Release Revision Number</u>		Key field Out / IN		
Description	This field contains the Release Revision Number.				
Processing outgoing EDI Sub-System	None				
ERP LN	Refers to data record SA3				
Processing Incoming EDI Sub-System	Transmission of the value from the message file.				
ERP LN	Refers to data record SA3				

Position	6	Field Format	n..6	Field Status	M
Field Name	<u>Release Position</u>		Key field Out / IN		
Description	This field contains the Release Position.				
Processing outgoing EDI Sub-System	None				
ERP LN	The release position is mapped from the ERP LN table field tdpur321.rpon to this position				
Processing Incoming EDI Sub-System	Transmission of the value from the message file.				
ERP LN	It is mapped to field tdsls308.cpon				

---

Position	7	Field Format	an..9	Field Status	M
Field Name	<u>Schedule Number</u>		Key field Out / In		
Description	This position contains the original Schedule Number				
Processing outgoing EDI Sub-System	None				
ERP LN	The schedule number is mapped from the ERP LN table field tdpur321.schn to this position.				
Processing Incoming EDI Sub-System	Transmission of the value from the message file.				
ERP LN	Mapped to table field tdsIs307.cchn				

Position	8	Field Format	n..4	Field Status	M
Field Name	<u>Release Position Detail</u>				
Description	This position identifies the position of a purchase release line detail; each release line detail refers to a separate release position number.				
Processing outgoing EDI Sub-System	None				
ERP LN	The detail number is mapped from the ERP LN table field tdpur322.posd to this position.				
Processing Incoming EDI Sub-System					
ERP LN	N. A.				

Position	9	Field Format	n..4	Field Status	M
<b>Field Name</b>	<b><u>Schedule Position</u></b>				

Description This field is only filled in shipments with schedule type pull-call off. It then contains the position on the referenced call-off.

Processing outgoing EDI Sub-System None

ERP LN The schedule number is mapped from the ERP LN table field tdpur322.spon to this position.

Processing Incoming EDI Sub-System Transmission of the value from the message file

ERP LN Mapped to table field tdsls307.cchp

Position	10	Field Format	n..22	Field Status	M
<b>Field Name</b>	<b><u>Start Date</u></b>				

Description This field contains the start date of the schedule line.

Processing outgoing EDI Sub-System None

ERP LN The schedule number is mapped from the ERP LN table field tdpur322.sdat to this position.

Processing Incoming EDI Sub-System Transmission of the value from the message file

ERP LN Mapped to table field tdsls307.sdat

---

Position	11	Field Format	n..22	Field Status	M
<b>Field Name</b>	<b><u>End Date</u></b>				

Description This field contains the end date of the schedule line.

Processing outgoing None  
EDI Sub-System

ERP LN The schedule number is mapped from the ERP LN table field tdpur322.edat to this position.

Processing Incoming Transmission of the value from the message file  
EDI Sub-System

ERP LN Mapped to table field tdsIs307.edat

Position	12	Field Format	an..9	Field Status	M
<b>Field Name</b>	<b><u>Requirement type</u></b>				

Description This field contains the requirement type of the schedule line's demand

Processing outgoing None  
EDI Sub-System

ERP LN The schedule number is mapped from the ERP LN table field tdpur322.rqty to this position after conversion by table ecedi465.  
The types 1 = immediate,  
2 = firm,  
3 = planned can be used.

Processing Incoming Transmission of the value from the message file  
EDI Sub-System

ERP LN Mapped to table field tdsIs307.ctyp after conversion by table ecedi365;  
for example the types 1 = immediate,  
2 = firm,  
3 = planned can be used.

Position	15	Field Format	an..6	Field Status	M
<b>Field Name</b>	<b><u>Qualifier Address Code</u></b>				

Description This position is used to store the default qualifier 1 for the Address code which is defined in the message definition.

Processing outgoing  
EDI Sub-System

None

ERP LN

This field will be filled with the constant value "ZZ".

Processing Incoming  
EDI Sub-System

ERP LN

This field will be filled with the constant value "ZZ".

Position	16	Field Format	n..19	Field Status	M
<b>Field Name</b>	<b><u>Quantity</u></b>				

Description This field includes the required quantity referring to the schedule line.

Processing outgoing  
EDI Sub-System

None

ERP LN

This field is mapped from the ERP LN table field tdpur322.qoor to this position.

Processing Incoming  
EDI Sub-System

Transmission of the value from the message file

ERP LN

Mapped to table field tdsis307.qoor

---



Position	17	Field Format	an..3	Field Status	M
<b>Field Name</b>	<b><u>Purchase / Sales Unit</u></b>				

Description	This field contains the item's purchase quantity unit.
Processing outgoing EDI Sub-System	None
ERP LN	This field is mapped from ERP LN table field tdpur322.cuqp to this position after conversion by ERP LN table ecedi442. If this field is blank then the unit defined in the data record SA3 should be used. If conversion not found then original value will be sent.
Processing Incoming EDI Sub-System	Transmission of the value from the message file
ERP LN	Mapped to table field tdsIs307.cuqs after conversion by table ecedi304

Position	18	Field Format	an..3	Field Status	M
<b>Field Name</b>	<b><u>Purchase / Sales Price Unit</u></b>				

Description	This field contains the item's price unit.
Processing outgoing EDI Sub-System	None
ERP LN	This field is mapped from ERP LN table field tdpur322.cupp to this position after conversion by ERP LN table ecedi442. If this field is blank then the unit defined in the data record SA3 should be used. If conversion not found then original value will be sent.
Processing Incoming EDI Sub-System	Transmission of the value from the message file
ERP LN	Mapped to table field tdsIs307.cups after conversion by table ecedi304

Position	19	Field Format	n..19	Field Status	M
<b>Field Name</b>	<b><u>Purchase / Sales Price</u></b>				

Description	This field contains the price in the given price unit.
Processing outgoing EDI Sub-System	None
ERP LN	This field is mapped from ERP LN table field tdpur322.price to this position.
Processing Incoming EDI Sub-System	Transmission of the value from the message file
ERP LN	Mapped to table field tdsls307.price.

Position	20	Field Format	an..3	Field Status	M
<b>Field Name</b>	<b><u>Tax Country</u></b>				

Description	This field contains the country code which is linked to the tax code.
Processing outgoing EDI Sub-System	None
ERP LN	The tax country code is mapped from ERP LN table field tdpur322.ccty to this position after conversion with ERP LN table ecedi440.
Processing Incoming EDI Sub-System	Transmission of the value from the message file.
ERP LN	Mapping to the ERP LN table field tdsls307.ccty after conversion with ERP LN table ecedi302.

Position	21	Field Format	an..9	Field Status	M
<b>Field Name</b>	<b><u>Tax Code</u></b>				

Description This field identifies the tax code.

Processing outgoing  
EDI Sub-System None

ERP LN The tax code is mapped from ERP LN table field tdpur322.cvat to this position after conversion by ERP LN table ecedi446.

Processing Incoming  
EDI Sub-System Transmission of the value from the message file.

ERP LN Mapping to the ERP LN table field tdsIs307.cvat after conversion by table ecedi308.

Position	22	Field Format	an..6	Field Status	C
<b>Field Name</b>	<b><u>Exempt Reason</u></b>				

Description This field contains the tax exempt reason code.

Processing outgoing  
EDI Sub-System None

ERP LN The exempt reason is mapped from ERP LN table field tdpur322.rcod to this position after conversion with ERP LN table ecedi495.

Processing Incoming  
EDI Sub-System Transmission of the value from the message file.

ERP LN Mapping to the ERP LN table field tdsIs307.rdoc after conversion with ERP LN table ecedi353.

Position	23	Field Format	an..20	Field Status	C
<b>Field Name</b>	<b><u>Exempt certificate</u></b>				
Description	This field contains the tax exempt certificate number.				
Processing outgoing EDI Sub-System	None				
ERP LN	The exempt reason is mapped from ERP LN table field tdpur322.ceno to this position.				
Processing Incoming EDI Sub-System	Transmission of the value from the message file.				
ERP LN	Mapping to the ERP LN table field tdsIs307.ceno				

Position	24	Field Format	n..8	Field Status	C
<b>Field Name</b>	<b><u>Length</u></b>				
Description	This field contains the length of the item based on an agreed physical unit.				
Processing outgoing EDI Sub-System					
ERP LN	The length from ERP LN table field tdpur322.leng is mapped to this position.				
Processing Incoming EDI Sub-System	Transmission of the value from the message file.				
ERP LN	Mapping to the ERP LN table field tdsIs307.leng.				

---

Position	25	Field Format	n..8	Field Status	C
Field Name	<u>Width</u>				
Description	This field contains the width of the item based on an agreed physical unit.				
Processing outgoing EDI Sub-System					
ERP LN	The width from ERP LN table field tdpur322.widt is mapped to this position.				
Processing Incoming EDI Sub-System	Transmission of the value from the message file.				
ERP LN	Mapping to the ERP LN table field tdsls307.widt.				

Position	26	Field Format	n..6	Field Status	C
Field Name	<u>Height</u>				
Description	This field contains the height of the item based on an agreed physical unit.				
Processing outgoing EDI Sub-System					
ERP LN	The height from ERP LN table field tdpur322.thic is mapped to this position.				
Processing Incoming EDI Sub-System	Transmission of the value from the message file.				
ERP LN	Mapping to the ERP LN table field tdsls307.thic.				

Position	27	Field Format	n..3	Field Status	M
<b>Field Name</b>	<b><u>Time Unit</u></b>				
Description	This field contains the time unit.				
Processing outgoing EDI Sub-System					
ERP LN	The height from ERP LN table field tdpu322.tiun is mapped to this position.				
Processing Incoming EDI Sub-System	Transmission of the value from the message file.				
ERP LN	Mapping to the ERP LN table field tdsls307.tiun.				

Position	28	Field Format	an..6	Field Status	M
<b>Field Name</b>	<b><u>Warehouse/Dock Location</u></b>				
Description	This field is only filled in shipments with schedule type pull-call off. In this case it contains the warehouse of the referenced call off.				
Processing outgoing EDI Sub-System					
ERP LN	The table field tdpur322.cwar is mapped to this position.				
Processing Incoming EDI Sub-System	Transmission of the value from the message file.				
ERP LN	Mapping to the ERP LN table field tdsls307.dock.				

Position	29	Field Format	an..9	Field Status	C
<b>Field Name</b>	<b><u>Reference ID</u></b>				
Description	This field is only filled in shipments with schedule type pull-call off. It then contains the reference ID of the referenced call off.				
Processing outgoing EDI Sub-System					
ERP LN	The table field tdpur322.caid is mapped to this position.				
Processing Incoming EDI Sub-System	Transmission of the value from the message file.				
ERP LN	Mapping to the ERP LN table field tdsls307.refe.				

---

Position	30	Field Format	an..6	Field Status	C
<b>Field Name</b>	<b><u>Exempt</u></b>				

Description This field contains a qualifier if tax exemption applies or not.

Processing outgoing  
EDI Sub-System

ERP LN The exempt qualifier from ERP LN table field tdpur322.exmt is mapped to this position.

Processing Incoming  
EDI Sub-System Transmission of the value from the message file.

ERP LN Mapping to the ERP LN table field tdsIs307.exmt.

Position	31	Field Format	an..3	Field Status	M
<b>Field Name</b>	<b><u>BP Tax Country</u></b>				

Description This field contains the tax country code of the Business Partner.

Processing outgoing  
EDI Sub-System None

ERP LN The business partner tax country code is mapped from ERP LN table tdpur322.bptc to this position after conversion with ERP LN table ecedi468.

Processing Incoming  
EDI Sub-System Transmission of the value from the message file.

ERP LN Mapping to the ERP LN table field tdsIs307.bptc after conversion with ERP LN table ecedi328.

Position	35	Field Format	an..6	Field Status	C
<b>Field Name</b>	<b><u>Manufacturer</u></b>				

Description This field contains the code of the good's supplier.

Processing outgoing  
EDI Sub-System None

ERP LN The code for the manufacturer from the ERP LN Table field tdpur322.cmnf is mapped to this position.

Processing Incoming  
EDI Sub-System

ERP LN N. A.

<b>Position</b>	<b>36</b>	<b>Field Format</b>	<b>an..35</b>	<b>Field Status</b>	<b>C</b>
<b>Field Name</b>	<b><u>Preferred Manufacturer's Part Number</u></b>				

Description The field contains the preferred manufacturer's part number for the item.

Processing outgoing  
EDI Sub-System None

ERP LN The code for the manufacturer's part number is mapped from the ERP LN Table field tdpur322.mpnr to this position.

Processing Incoming  
EDI Sub-System

ERP LN N. A.

<b>Position</b>	<b>37</b>	<b>Field Format</b>	<b>an7</b>	<b>Field Status</b>	<b>M</b>
<b>Field Name</b>	<b><u>Data Record end sign</u></b>		<b>Key field Out / IN</b>		

Description This field identifies the end of data record in the message block. It contains the constant value 'SA6\_END'.

Processing outgoing  
EDI Sub-System

ERP LN This field will be filled with the constant value 'SA6\_END'.

Processing Incoming  
EDI Sub-System This field will be filled with the constant value 'SA6\_END'.

ERP LN None

---



---

## Chapter 3 Definitions, Acronyms, and Abbreviations

# 3

<b>Term</b>	<b>Description</b>
ANSI X12	American National Standards Institute Accredited Standards Committee X12; Standard definitions of American EDI Directories
BEM	Baan Electronic Message - abbreviated form of BEMIS used with the definition of the EDI organization
BEMIS	“BAAN Electronic Message Interchange System”; it is used for the ERP LN In-house EDI format
BP	Business Partner; used for Customer and Supplier
EDI	Electronic Data Interchange; electronic exchange of documents in standard formats
EDIFACT	Electronic Data Interchange for Administration, Commerce and Transport; Standard definitions of United Nations Directories
GLN	Global Location Number, a thirteen digit number used to identify legal entities, trading parties and locations.
ID	Identification
ILN	International Location Number; see GLN
MRL	Material Release
SEQ	Shipping Sequence Schedule
SHP	Shipping Schedule
VDA	The German Association of the Automotive Industry; Standard definitions of German EDI Directories

---





